

Walking on the Arrangement, not on the Feasible Region

Komei Fukuda

ETH Zurich, Switzerland

fukuda@ifor.math.ethz.ch

<http://www.ifor.math.ethz.ch/~fukuda/>

January 2011

Linear Programming Problem (LP)

(Given $A \in \mathbb{R}^{m \times d}$, $b \in \mathbb{R}^m$, $c \in \mathbb{R}^d$)

$$\begin{array}{l|l} \text{LP: } \max & c^T x \\ & \text{subject to } Ax \leq b \end{array} \quad \left| \quad \begin{array}{l} = \sum_{j=1}^d c_j x_j \\ \sum_{j=1}^d a_{ij} x_j \leq b_i, \forall i = 1, \dots, m \end{array} \right.$$

The feasible region $\{x : Ax \leq b\}$ is a convex polyhedron.

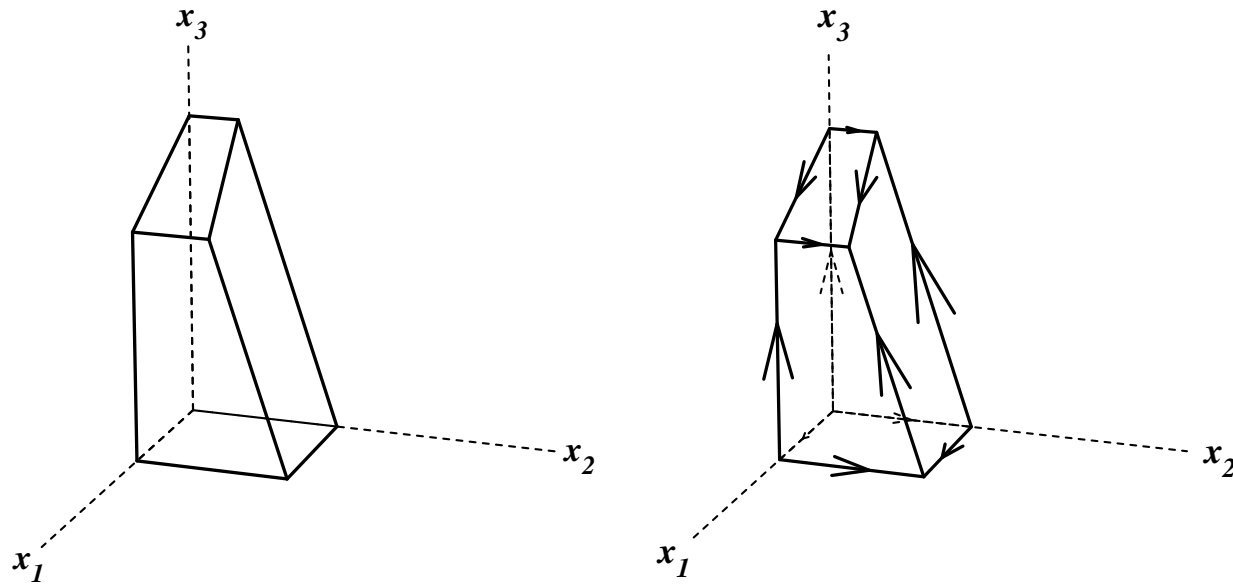

Three Algorithms for Linear Programming

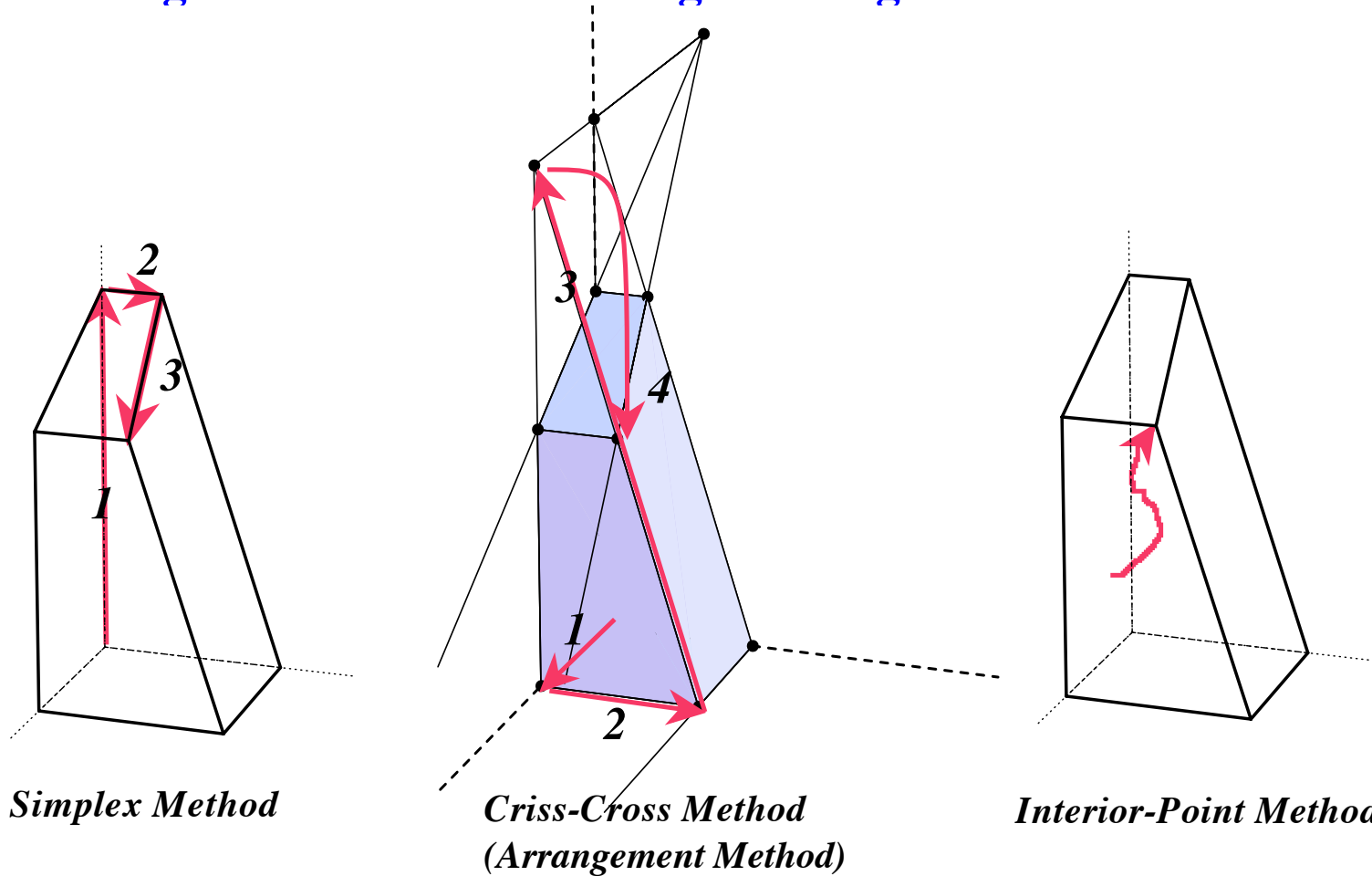

All existing polynomial algorithms are of interior-point/ellipsoid type.

Our ultimate goal is to find a strongly polynomial algorithm.

Outline of This Talk

- The simplex method can be considered as an arrangement method (Hazan-Megiddo).
- The criss-cross method is an arrangement method with many nice (and some annoying) properties.

Diameters of the Feasible Region and the Arrangement

$d = 2, m = 5$

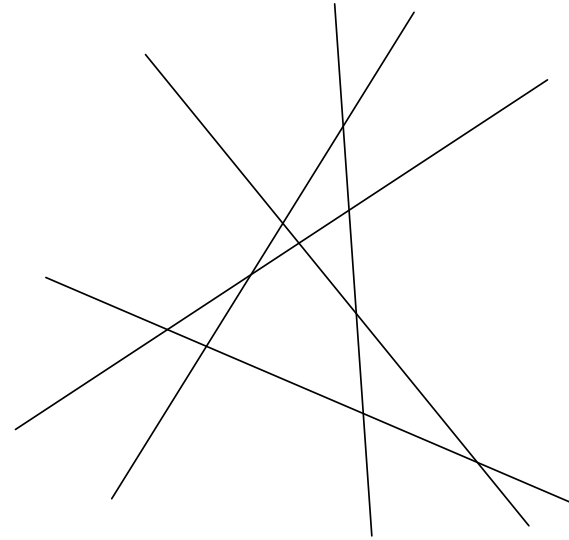
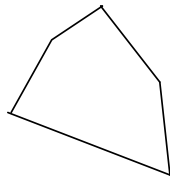

The feasible region $P \subset \mathbb{R}^d$

The arrangement A of m hyperplanes

No known polynomial bound for P : $\text{diam}(P) \leq \text{poly}(m, d)???$

A simple quadratic bound exists for A : $\text{diam}(A) = O(m d)$

(If all vertices on a 1-flat are considered adjacent, $\text{diam}(A) \leq d$)

Simplex Method on the Arrangement

$$d = 2, m = 5$$

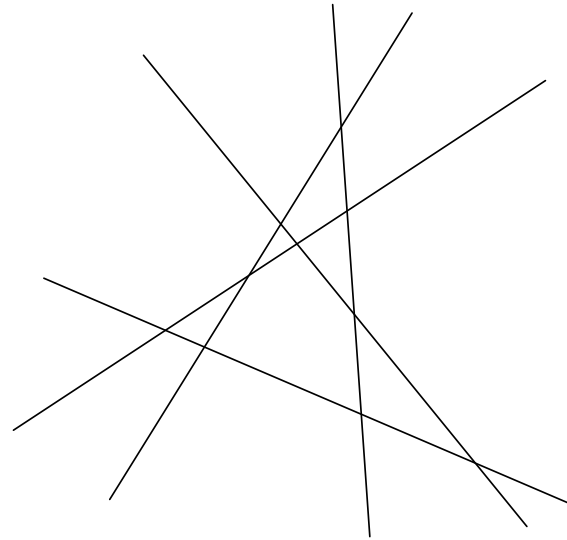
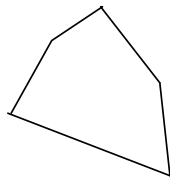

Hazan-Megiddo (2007) showed the Phase I of the simplex method can be set up in such a way that it traces the graph of the arrangement.

(This was used to show Koltun's arrangement method (2007) is a special case of the Phase I.)

It follows that the existence of a strongly polynomial simplex method on this Phase I implies the strongly polynomial solvability of LP, but does not imply any polynomial bound for $\text{diam}(P)$.

Simplex Method on the Arrangement

Phase I for the feasible region: $Ax \geq b$

The standard way is to set up a feasible LP:

$$\begin{aligned} \min \quad & x_0 && (x \in \mathbb{R}^d, x_0 \in \mathbb{R}) \\ \text{s.t.} \quad & Ax + 1x_0 \geq b \\ & x_0 \geq 0. \end{aligned}$$

Let P_1 be its feasible region $\{(x, x_0) : Ax + 1x_0 \geq b, x_0 \geq 0\} \subseteq \mathbb{R}^{d+1}$.

Hazan-Megiddo (2007) considers another feasible LP:

$$\begin{aligned} \min \quad & 1^T s && (x \in \mathbb{R}^d, s \in \mathbb{R}^m) \\ \text{s.t.} \quad & Ax + s \geq b \\ & s \geq 0. \end{aligned}$$

Let P_2 be its feasible region $\{(x, s) : Ax + s \geq b, s \geq 0\} \subseteq \mathbb{R}^{d+m}$.

Simplex Method on the Arrangement

Theorem of Hazan-Megiddo (2007):

The graph of the Phase I polyhedron P_2 is isomorphic to that of the arrangement A of the original LP, when the unbounded rays are ignored.

More precisely, (under a nondegeneracy assumption), they showed

- There is a one-to-one correspondence between the vertices of P_2 and the vertices of A , preserving the adjacency.

Therefore, the simplex method for this Phase I will follow the graph of the arrangement whose diameter is $O((d + m) d) = O(m d)$.

One interesting problem:

- Analyse the complexity of the simplex method for this Phase I.

Simplex Method on the Arrangement

A Key Lemma.

Let (\hat{x}, \hat{s}) be a vertex of $P_2 = \{(x, s) : Ax + s \geq b, s \geq 0\}$. Then,

- (1) At least $d + m$ inequalities are tight at (\hat{x}, \hat{s}) ,
- (2) $\hat{s}_i = \max\{0, b_i - A_i\hat{x}\}$ for all $i = 1, \dots, m$,
- (3) $\hat{s}_i = b_i - A_i\hat{x} = 0$ for at least d values of i .

Proof of (3). For each $i = 1, \dots, m$, either

- (a) $\hat{s}_i = b_i - A_i\hat{x} > 0$,
- (b) $\hat{s}_i = 0$ and $b_i - A_i\hat{x} < 0$, or
- (c) $\hat{s}_i = 0$ and $b_i - A_i\hat{x} = 0$.

While each of (a) and (b) generates one tight inequality, (c) generates two tight inequalities. Then, (3) follows from this and (1).

The Simplex Method

\oplus	
\vdots	
\oplus	



	s $+$
\oplus	
\vdots	
\oplus	



	s $+$
\oplus	
\vdots	
\oplus	$-$

ratio test

↓ pivot on (r, s)

new feasible dictionary



	$\ominus \dots \ominus$
\oplus	
\vdots	
\oplus	

stop: optimal



	s $+$
\oplus	\oplus
\vdots	\vdots
\oplus	\oplus

stop: unbounded

Admissible Pivots and the Criss-Cross Method

Admissible Pivots

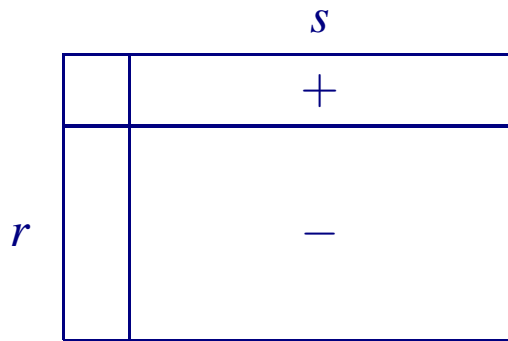

admissible type I

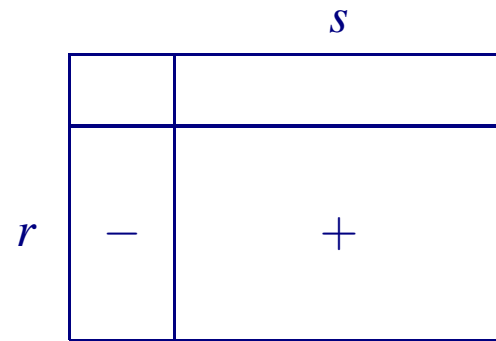

admissible type II

The simplex method is an admissible pivot method of type I.

The dual simplex method is an admissible pivot method of type II.

The criss-cross method is the least-index admissible pivot method, due to Terlaky (1985) and Wang (1987). It is a finite self-dual method which may not preserve feasibility. There are a few variations, some of which are history dependent.

Some Facts about Admissible Pivot Methods

Theorem [Roos (1990)]. The criss-cross method may visit all 2^d vertices of the Klee-Minty cube.

Theorem [F.-Kaluzny (2004)]. The criss-cross method may visit $\Omega(m^d)$ vertices of the arrangement of an LP.

Theorem [F.-Terlaky (2000)]. There exists a sequence of at most m admissible pivots from any basis to some optimal basis, whenever an LP has an optimal solution.

Theorem [F.-Terlaky (1992)]. The criss-cross method can be extended to solve the convex QP and the LCP with sufficient matrices.

Remark 1. Not much is known for the behavior of the randomized criss-cross method for linear programming.

Remark 2. There are a few cases of LCP for which the randomized criss-cross method is known to be (expected) polynomial.

Convex Quadratic Programming Problem (convex QP)

(Given $A \in \mathbb{R}^{m \times d}$, $G \in \mathbb{R}^{d \times d}$: positive semidefinite, $b \in \mathbb{R}^m$, $c \in \mathbb{R}^d$)

$$\begin{aligned} \text{QP: } \quad & \max && c^T x - \frac{1}{2} x^T G x \\ & \text{subject to} && A x \leq b \\ & && x \geq 0. \end{aligned}$$

The convex QP (and the LP) admits a certificate for optimality.

Theorem [QP Duality Theorem, Cottle 1963]

If the QP has an optimal solution, then its dual QD:

$$\begin{aligned} \text{QD: } \quad & \min && b^T y + \frac{1}{2} x^T G x \\ & \text{subject to} && Gx + A^T y \geq c \\ & && y \geq 0 \end{aligned}$$

has an optimal solution and the optimal values are equal. Moreover x values of the optimal solutions can be taken to be the same.

Convex Quadratic Programming Problem (convex QP)

All algorithms solving the convex QP (and the LP) aim at finding this certificate (i.e. primal and dual solutions).

Moreover, this optimality is equivalent to the Karush-Kuhn-Tucker (KKT) conditions:

Primal	$Ax \leq b$,	$y \geq 0$	Dual
Feasibility	$x \geq 0$,	$Gx + A^T y \geq c$	Feasibility
	$A_i x = b_i$	or	$y_i = 0$	$\forall i$ Complementary
	$x_j = 0$	or	$(Gx + A^T y)_j = c_j$	$\forall j$ Slackness

Linear Complementarity Problem with Sufficient Matrices (S-LCP)

(Given a sufficient matrix $M \in \mathbb{R}^{n \times n}$, $q \in \mathbb{R}^n$)

LCP: find two vectors $w, z \in \mathbb{R}^n$ satisfying

$$w = Mz + q,$$

$$w \geq 0, z \geq 0, \text{ and}$$

$$w^T z = 0.$$

The convex QP is a special case of S-LCP, because the KT conditions can be written as LCP with

$$M = \begin{bmatrix} 0 & -A \\ A^T & G \end{bmatrix}, \quad q = \begin{bmatrix} b \\ -c \end{bmatrix}$$

Because G is PSD, the matrix M is sufficient.

Sufficient Matrices and LCP

A matrix M is called column sufficient if

$$[z_i(Mz)_i \leq 0 \text{ for all } i] \implies [z_i(Mz)_i = 0 \text{ for all } i] .$$

A matrix M is called row sufficient if M^T is column sufficient, and sufficient if both column and row sufficient.

- Many LP algorithms (e.g. simplex, criss-cross, interior-point) can be generalized to solve sufficient-matrix LCPs (S-LCPs).
- There is an interior-point algorithm that runs in time polynomial in the size of input and one parameter κ (that is not bounded from above), due to Kojima, Megiddo, Noma and Yoshise (1991).
- No algorithm is known to run in polynomial time.
- If S-LCP is NP-hard, it implies NP=co-NP that is unlikely.

LCP and Complementarity Bases

LCP(M, q): find two vectors $w, z \in \mathbb{R}^n$ satisfying

$$\begin{bmatrix} I & -M \end{bmatrix} \begin{pmatrix} w \\ z \end{pmatrix} = q,$$

$$w \geq 0, z \geq 0, \text{ and}$$

$$w^T z = 0.$$

Pivoting in LCP: Try to determine whether $w_i = 0$ or $z_i = 0$ for each i at a solution, or to prove no solution exists.

A complementary basis B of $\begin{bmatrix} I & -M \end{bmatrix}$ consists of either i th column of I or $-M$, for each column i .

If $Bx = q$ has a non-negative solution, we have a solution for the LCP. Otherwise, make some pivot(s) to move to an adjacent complementary basis.

Morris's LCP

$$M = \begin{pmatrix} 1 & 2 & 0 & \dots & 0 & 0 & 0 \\ 0 & 1 & 2 & \dots & 0 & 0 & 0 \\ 0 & 0 & 1 & \dots & 0 & 0 & 0 \\ & & & \ddots & & & \\ 0 & 0 & 0 & \dots & 1 & 2 & 0 \\ 0 & 0 & 0 & \dots & 0 & 1 & 2 \\ 2 & 0 & 0 & \dots & 0 & 0 & 1 \end{pmatrix}, \quad q = \begin{pmatrix} -1 \\ -1 \\ -1 \\ \vdots \\ -1 \\ -1 \\ -1 \end{pmatrix}.$$

Morris's LCP for $n = 3$

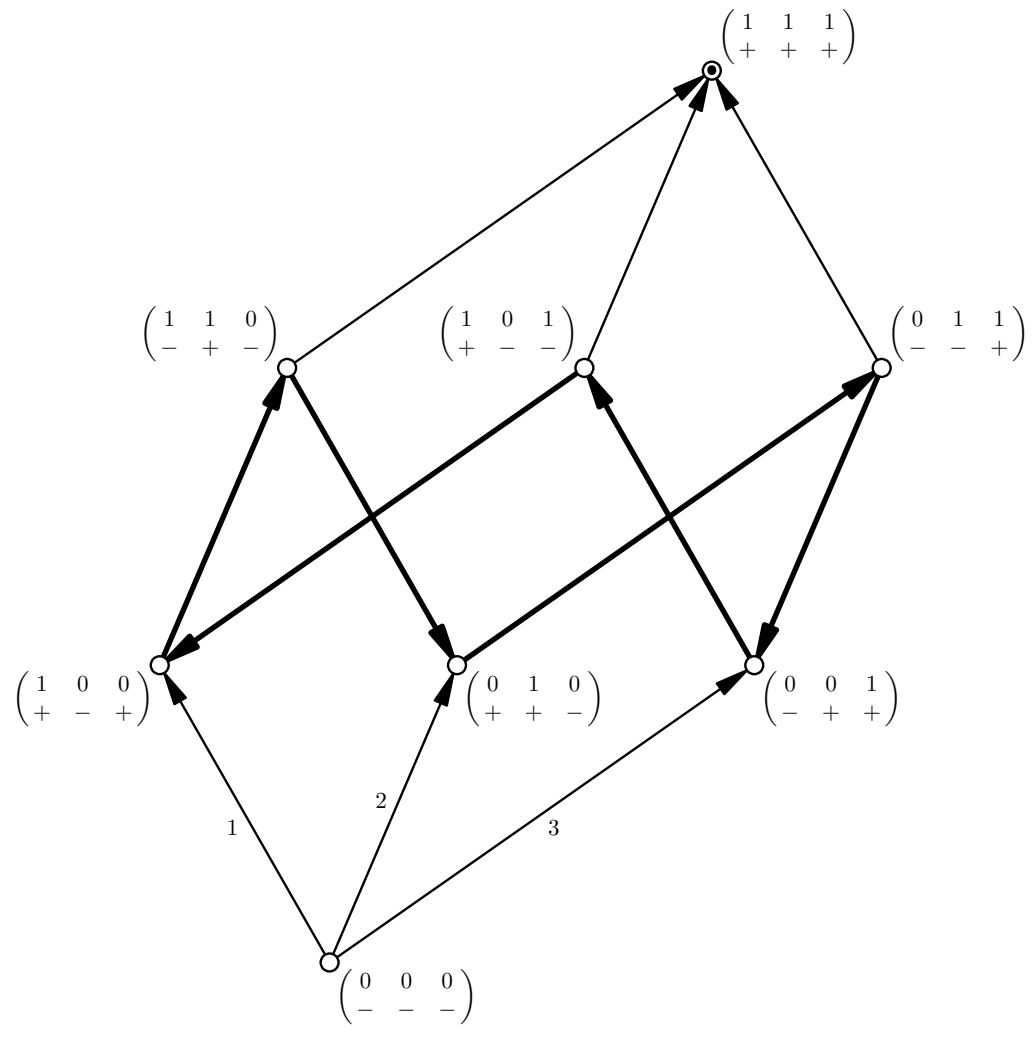

The Criss-Cross Method

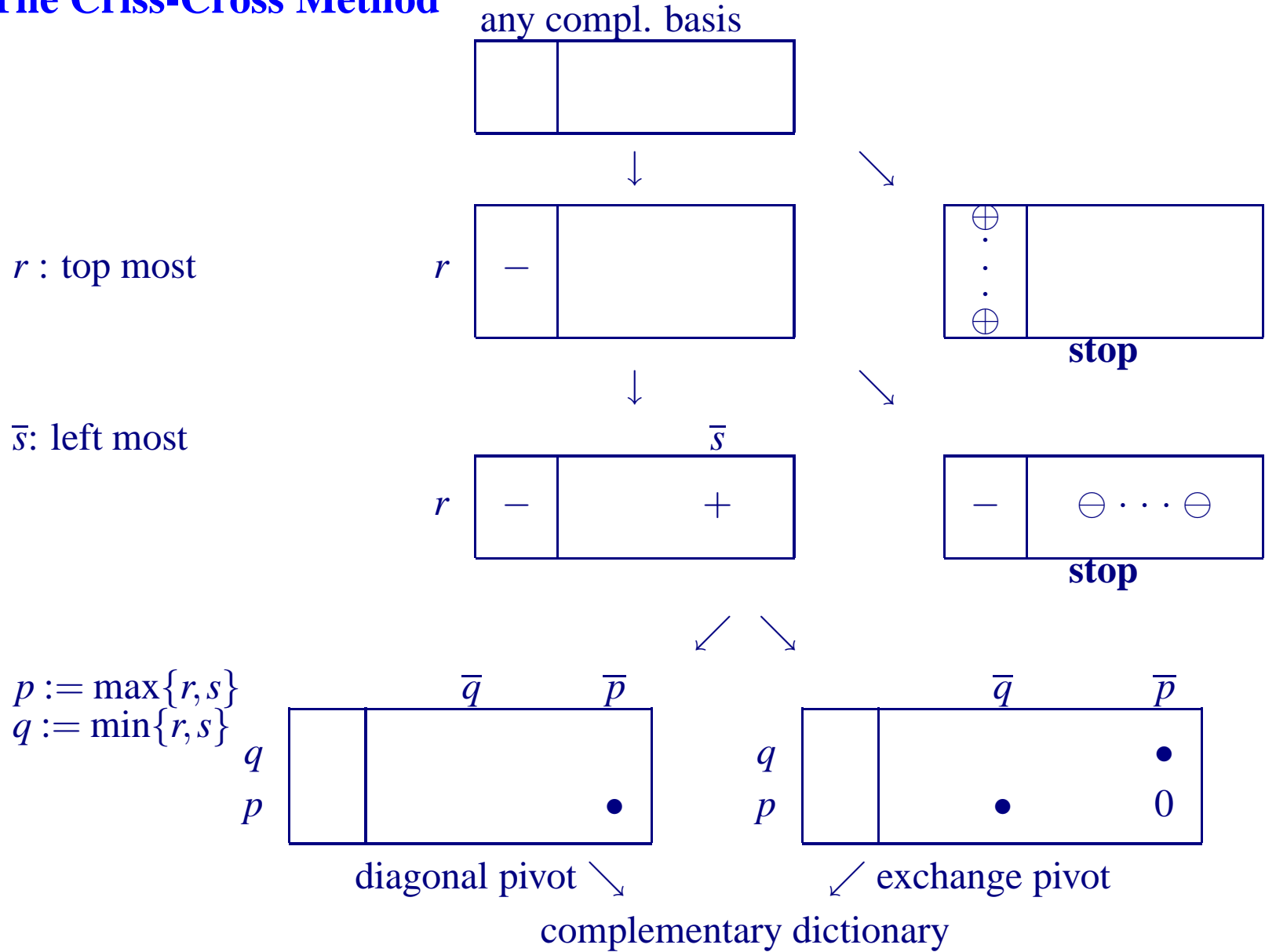

Murty's LCP (1978)

$$M = \begin{pmatrix} 1 & 2 & 2 & \dots & 2 & 2 \\ 0 & 1 & 2 & \dots & 2 & 2 \\ 0 & 0 & 1 & \dots & 2 & 2 \\ & & & \ddots & & \\ 0 & 0 & 0 & \dots & 1 & 2 \\ 0 & 0 & 0 & \dots & 0 & 1 \end{pmatrix}, \quad q = \begin{pmatrix} -1 \\ -1 \\ -1 \\ \vdots \\ -1 \\ -1 \end{pmatrix}.$$

- The associated orientation of the cube is isomorphic to the Klee-Minty cube.
- The criss-cross method (and Murty's least index method) takes $2^n - 1$ pivots for Murty's LCP.
- F.-Namiki (1994) showed that the **randomized** criss-cross takes exactly (expected) n pivots.

Morris's LCP (2002)

$$M = \begin{pmatrix} 1 & 2 & 0 & \dots & 0 & 0 & 0 \\ 0 & 1 & 2 & \dots & 0 & 0 & 0 \\ 0 & 0 & 1 & \dots & 0 & 0 & 0 \\ & & & \ddots & & & \\ 0 & 0 & 0 & \dots & 1 & 2 & 0 \\ 0 & 0 & 0 & \dots & 0 & 1 & 2 \\ 2 & 0 & 0 & \dots & 0 & 0 & 1 \end{pmatrix}, \quad q = \begin{pmatrix} -1 \\ -1 \\ -1 \\ \vdots \\ -1 \\ -1 \\ -1 \end{pmatrix}.$$

- Morris (2002) proved that the randomized edge (principal pivot) method takes at least $\frac{(n-1)!}{2}$ pivots on average for Morris's LCP. (The associated unique sink orientation is highly cyclic.)
- Foniok-F.-Gärtner-Lüthi (2008) showed that the criss-cross method with any permutation of variables takes at most $O(n^2)$ pivots.

Morris's LCP for $n = 3$

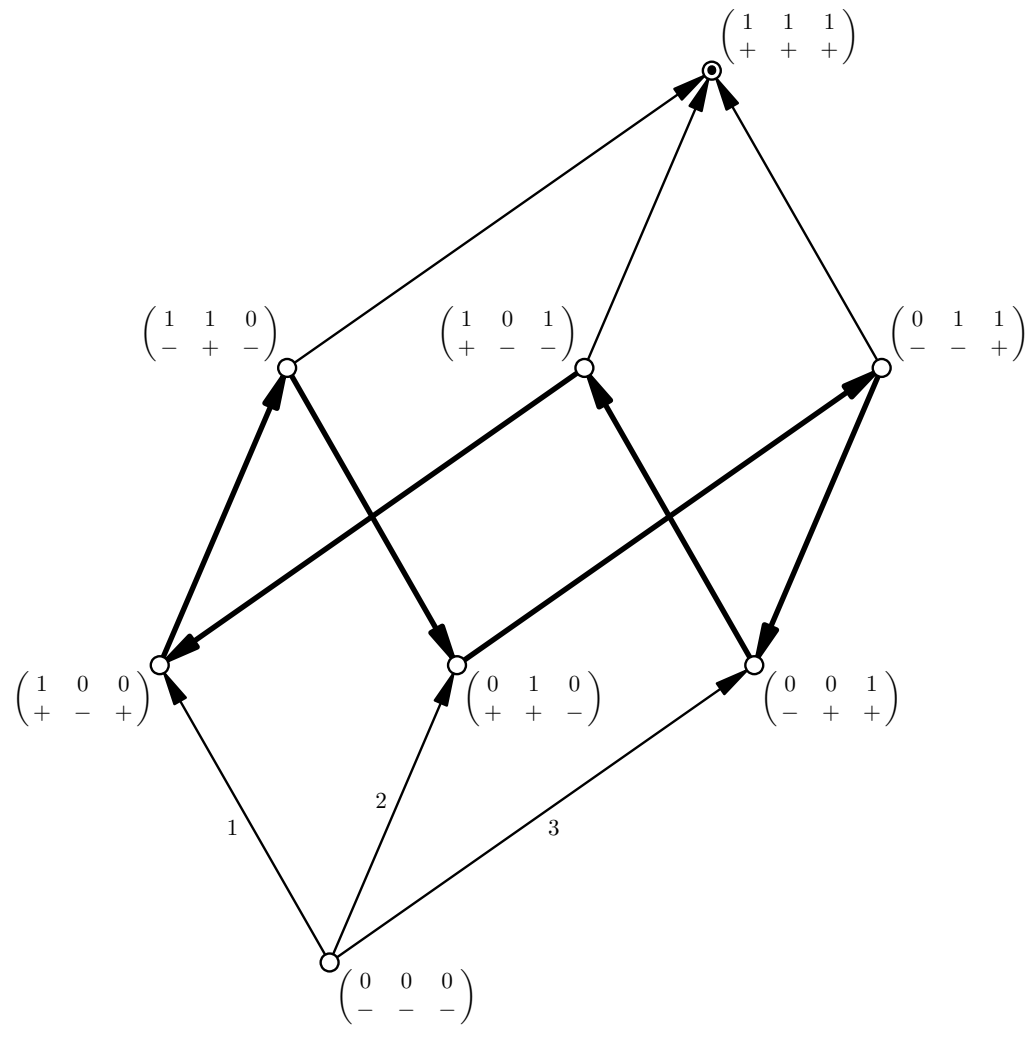

Conjecture (F.)

The randomised criss-cross method is an expected strongly polynomial-time algorithm for S-LCP.

Award for the resolution: A nice bottle of wine!