

Fluctuating Hydrodynamics Approaches for Lipid Bilayer Membranes

Partial Order: Mathematics, Simulations and Applications.

**Institute for Pure & Applied Mathematics
(IPAM-UCLA)**

January 2016

Paul J. Atzberger

Department of Mathematics

Department of Mechanical Engineering

University of California Santa Barbara

Lipid Bilayer Membranes : Amphiphilic Molecules

Cell Membranes

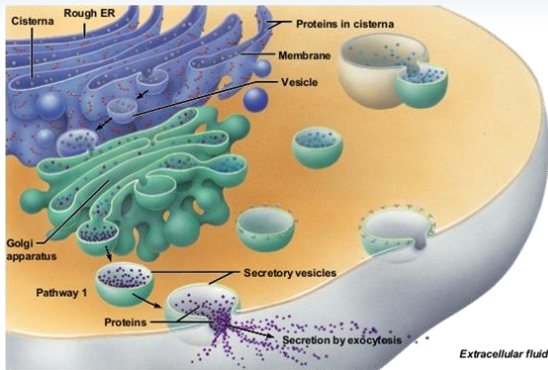

Phosphoglyceride

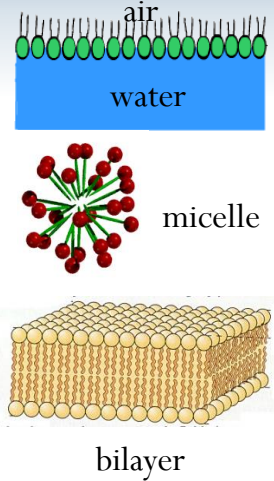
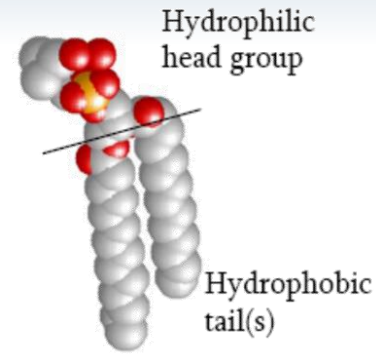
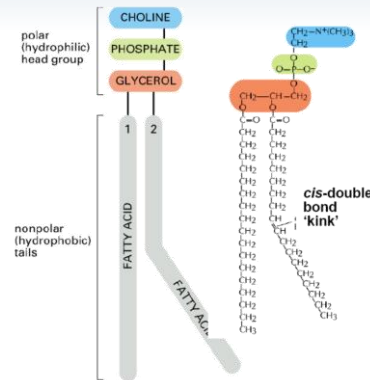

Lipid Bilayer Membranes

- Cellular biology : membranes compartmentalize cell, dynamic structures, diverse functions.
- Fluid phase two layered structure (bilayer).
- Mechanics of a fluid-elastic sheet (in-plane flow, elastic response to bending).
- Phenomena span wide temporal-spatial scales.

Amphiphilic Molecules (Lipids)

- Amphiphiles have a polar head (hydrophilic) and non-polar tail (hydrophobic).
- Solvent plays key role driving self-assembly (hydrophobic-hydrophilic effect).
- Phases fluid vs gel, micelle vs lamellar, size of polar vs non-polar part.

Partially Ordered Structures

- Lyotropic liquid crystals (temperature and concentration determines phase).
- Smectic A and C phases (translational order in layers, orientation orthogonal/tilt in layer).
- Lamellar sheets most relevant to biology, but many other phases possible.

Phases for Lipid Systems

Fig. Source: D. Cleaver Sheffield, Hallam University

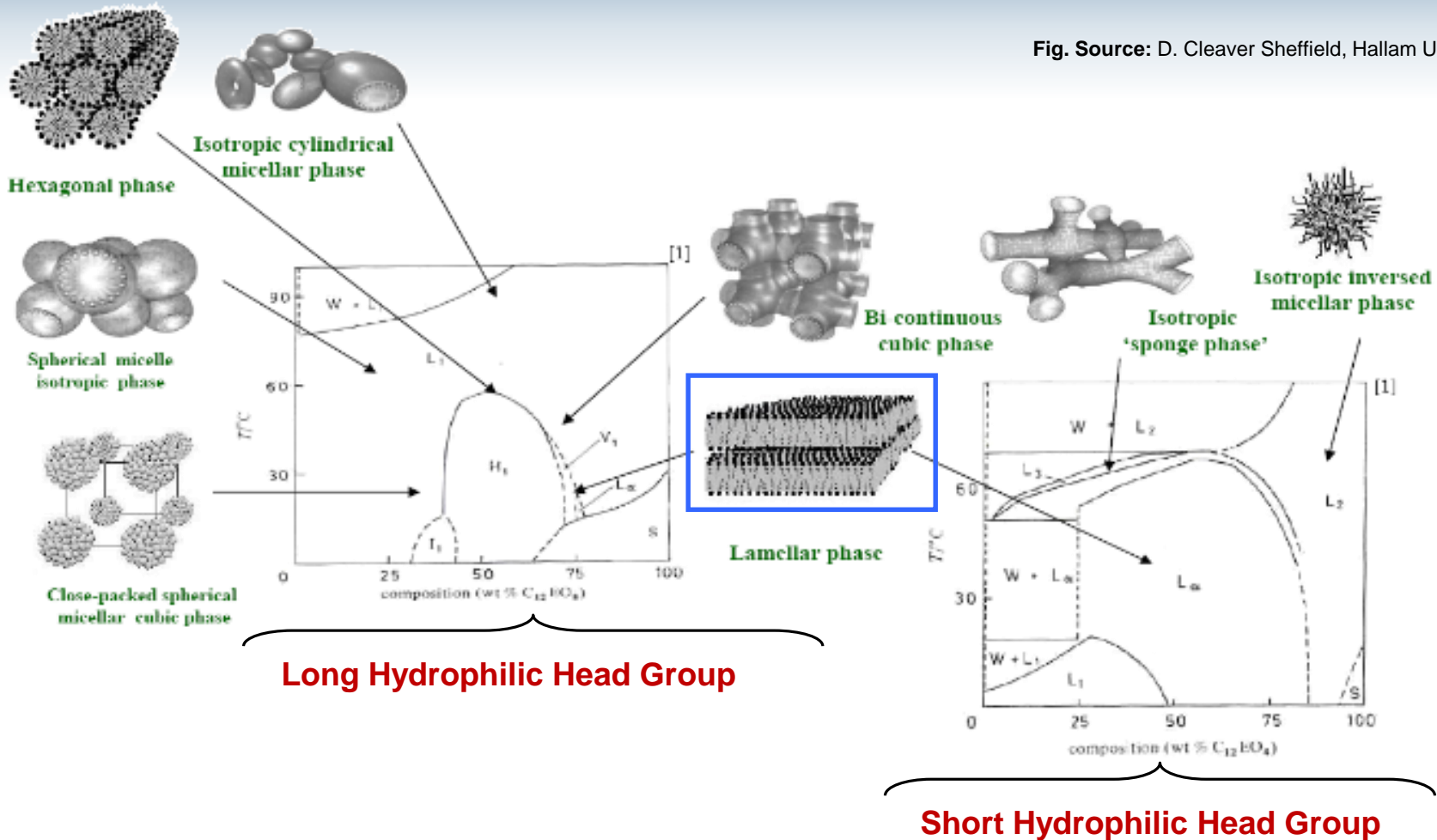

Lipid Phases

- Polar and non-polar lengths of molecule play role in phase.
- Many other applications of lipids i.e. in household products (hair gels, hand lotion, shampoo).
- Lamellar and micelle phases appear most relevant to biology.
- Lamellar phase appears more common with short hydrophilic head and longer hydrophobic tail.

Modeling Approaches for Lipid Bilayer Membranes

Atomistic Molecular Dynamics

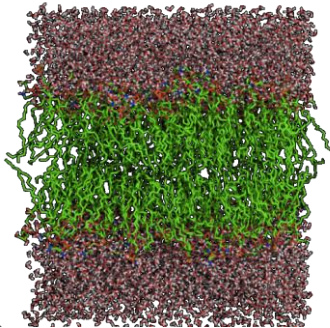

Grossfield 2013

Coarse-Grained Explicit-Solvent

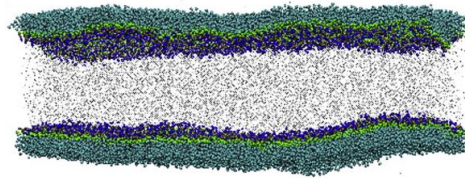

Duncan 2012

Coarse-Grained Implicit-Solvent

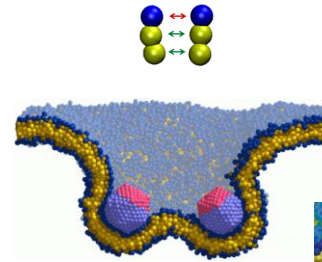

Deserno 2007

Continuum Mechanics Hydrodynamics

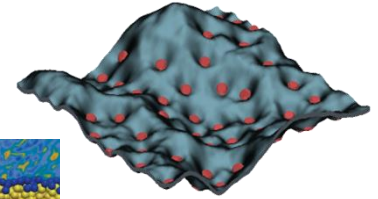

Atzberger 2013

Atzberger et al. 2009
Atzberger & Sigurdsson 2013

Atomistic Molecular Dynamics

- Representation of solvent fluid molecules and lipids.
- Atomic detail of molecules.
- Limited length and time-scales.

Explicit-Solvent Coarse-Grained (ES-CG)

- Atoms grouped/represented by coarse-grained units.
- Effective free-energy of interaction used on remaining degrees of freedom (DOF).
- Reduces entropy of the system (caution).
- Smooths energy landscape with often less stiff dynamics.
- Explicit-solvent is expensive, still requires resolving molecules of the bulk.

Implicit-Solvent Coarse-Grained (IS-CG)

- Atoms grouped/represented by coarse-grained units.
- Effective free-energy of interaction used on remaining degrees of freedom (DOF).
- Used widely for equilibrium studies, however, dynamics augmented by missing solvent effects.
- To extend for kinetic studies, need thermostats to account for correlation contributions of solvent in IS-CG.

Soft Materials Simulation

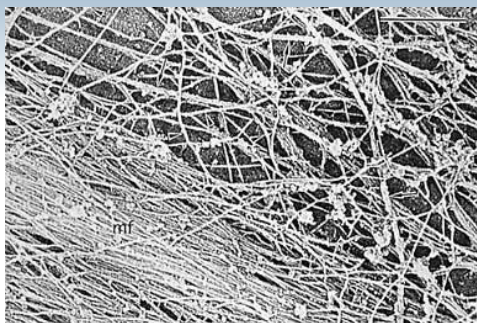

Gels (Actin)

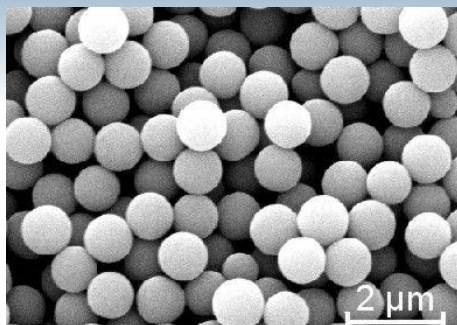

Colloids

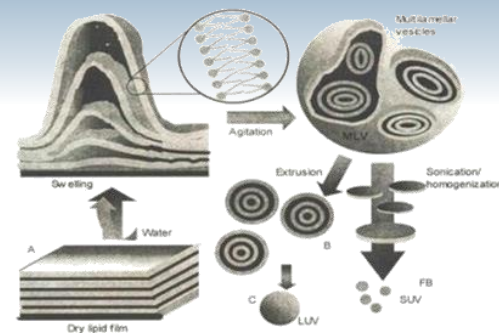

Membranes (lipids)

Soft Materials

- Interactions on order of $k_B T$.
- Properties arise from balance of entropy-enthalpy.
- Solvent plays important role (interactions / responses).
- Phenomena span wide temporal-spatial scales.

Approaches

- Atomistic Molecular Dynamics.
- Continuum Mechanics.
- Coarse-Grained Particle Models (solvated / implicit).

Simulation Methods / Thermostats

- NVE vs NVT ensembles.
- NVE \rightarrow Velocity-Verlet (no thermostat).
- NVT \rightarrow Berendsen, Nose-Hoover (artificial dynamics).
- NVT \rightarrow Langevin Dynamics (kinetics?).

• What about solvent mediated kinetics? What about other ensembles (NPT, $\dot{\gamma}$ VT)?

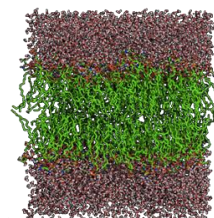
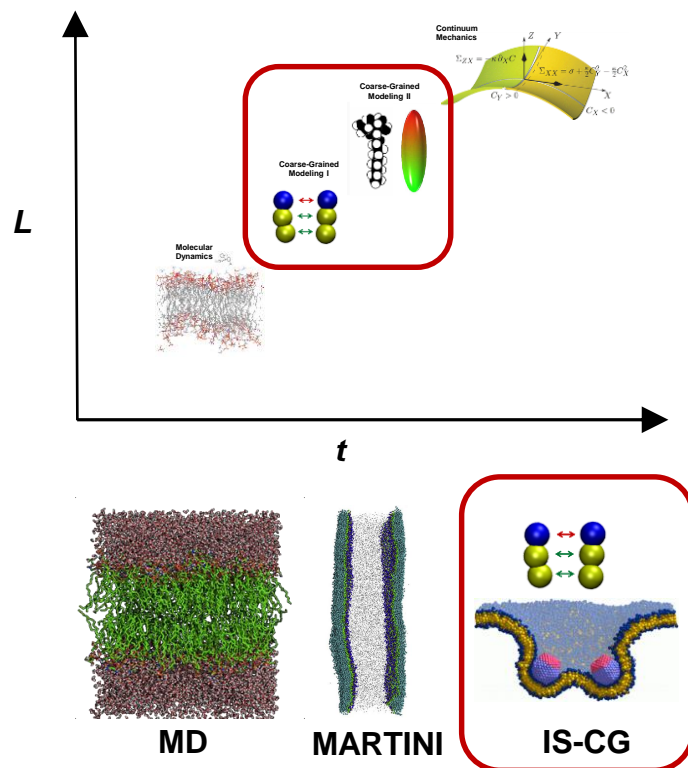

MD

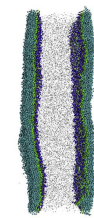

MARTINI

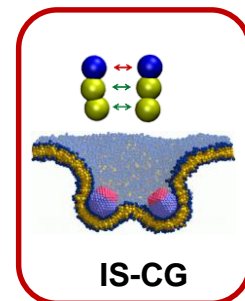

IS-CG

Model Resolution

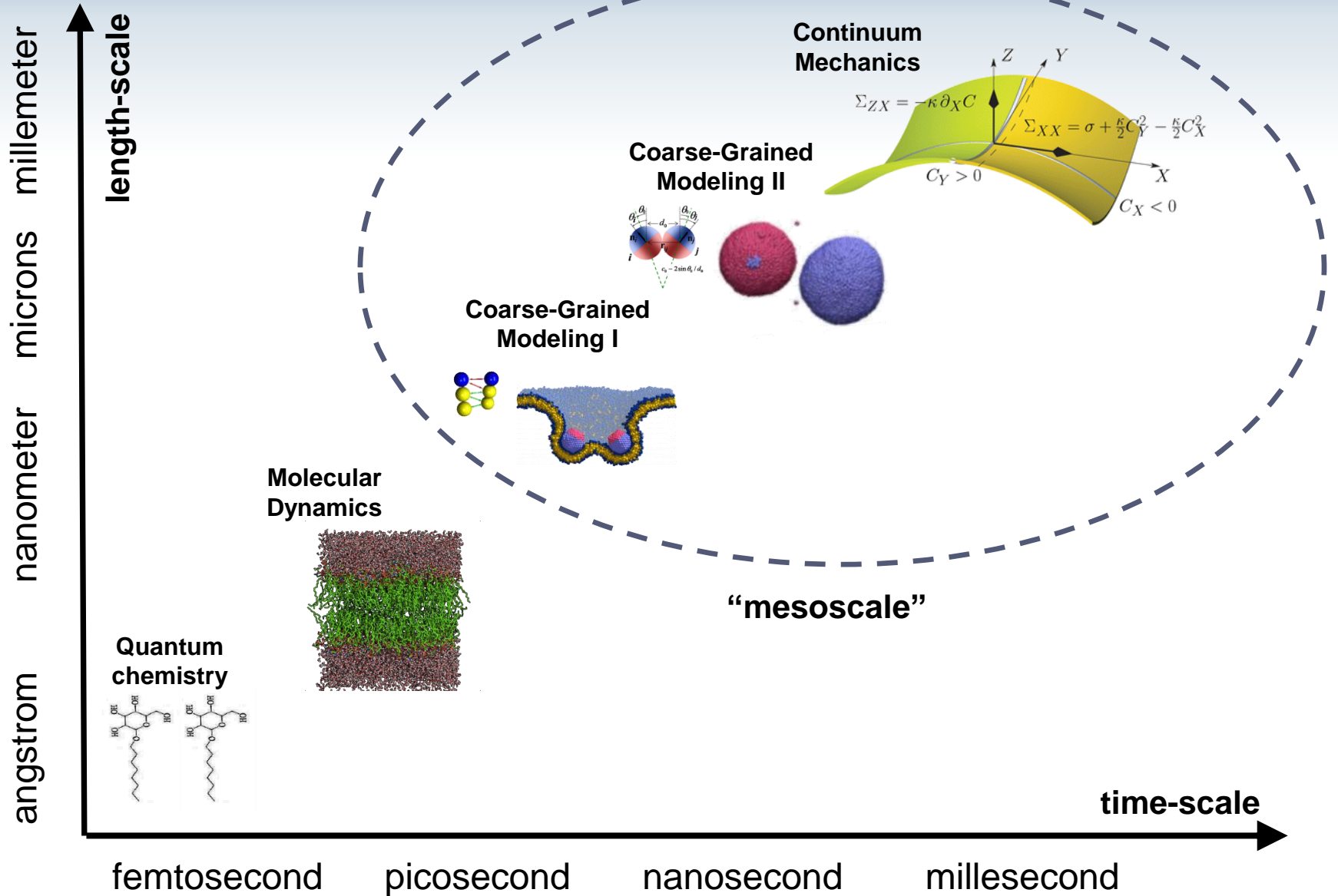

Solvent Hydrodynamics
CFD Fluid-Structure Interactions

Fluid-Structure Interactions

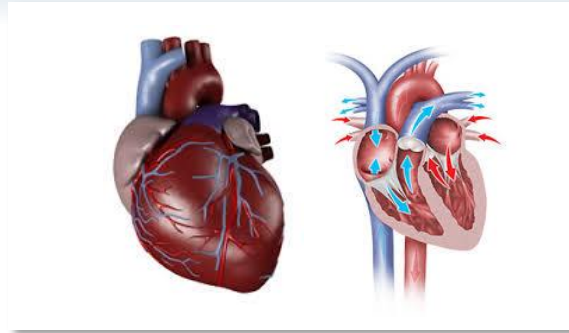

David Rogers

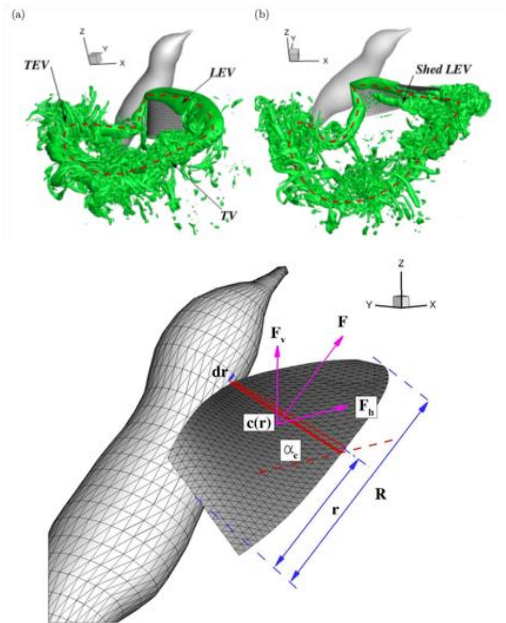

Song, J., Luo, H., Hedrick, T.L.

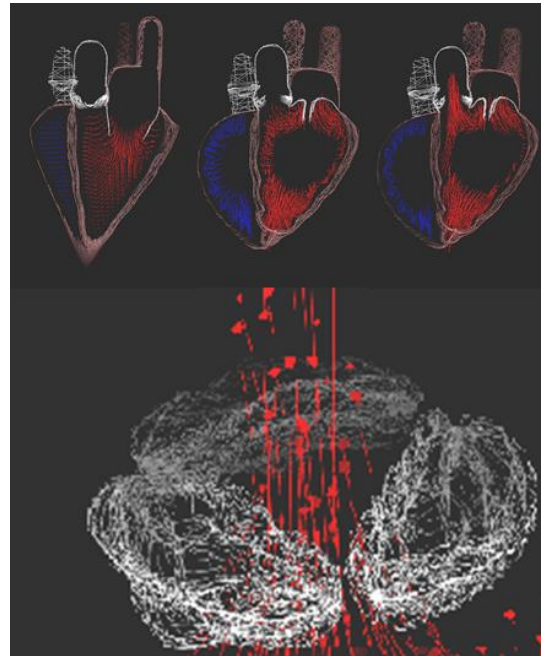

Peskin, C and McQueen, D. et al.

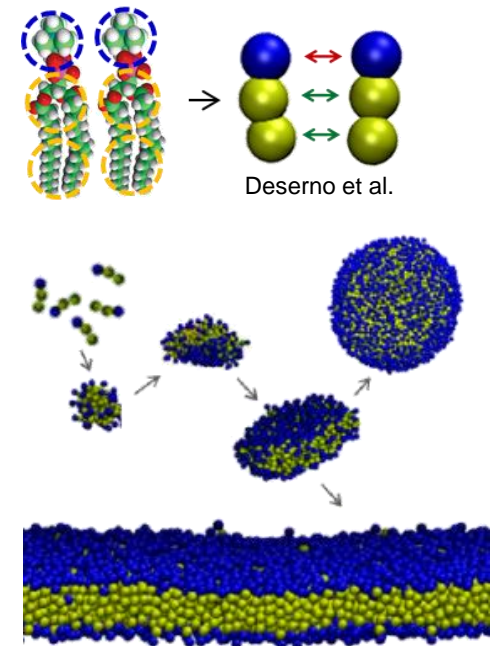

Deserno et al.

Atzberger, P., Sigurdsson, J. et al.

CFD : Approaches

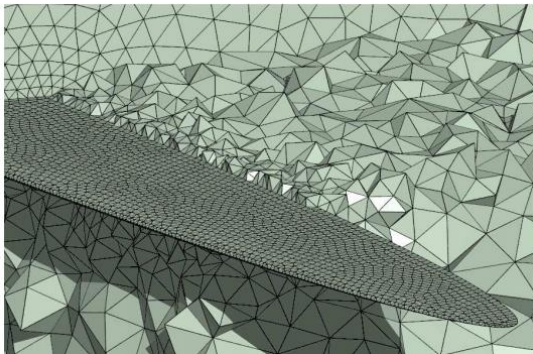
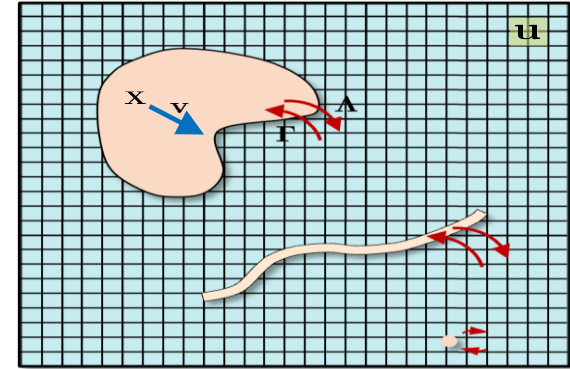
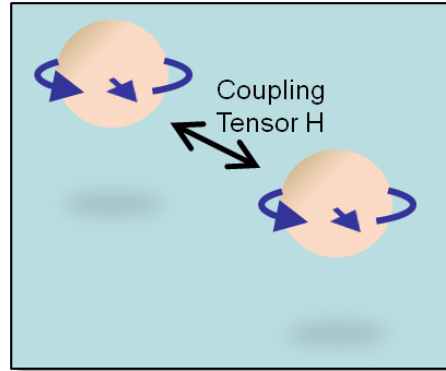
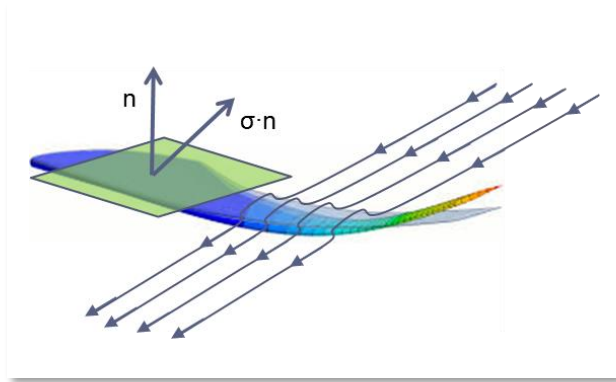

J. Peraire and P.-O. Persson



Brady et al., G. Gompper et al.

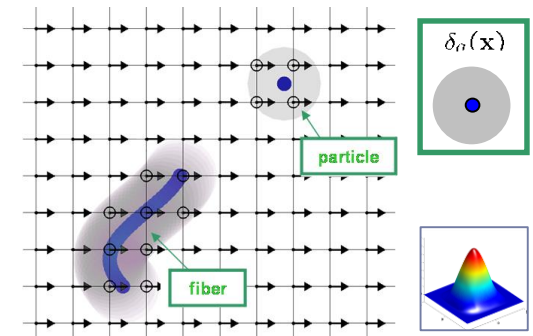

Atzberger, Peskin, Kramer

Thermostats

Berendsen, Nose-Hoover

particle momentum



particle momentum



heat bath

Langevin

particle momentum



X
(sink)



thermal
fluctuations
(stochastic)

$$m \frac{d\mathbf{V}}{dt} = -\gamma \mathbf{V} - \nabla \Phi(\mathbf{X}) + \sqrt{2k_B T \gamma} \frac{d\mathbf{B}_t}{dt}$$

$$\frac{d\mathbf{X}}{dt} = \mathbf{V}.$$

missing correlations through solvent!

Fluctuating Hydrodynamics

particle momentum



solvent
(fluid modes)



solvent
(fluid fluctuations)

$$\frac{d\mathbf{X}}{dt} = \mathbf{v}$$

$$m \frac{d\mathbf{v}}{dt} = -\Upsilon (\mathbf{v} - \Gamma \mathbf{u}) - \nabla_{\mathbf{X}} \Phi[\mathbf{X}] + \zeta + \mathbf{F}_{\text{thm}}$$

lateral momentum transfer : correlations

Fluctuating Hydrodynamics

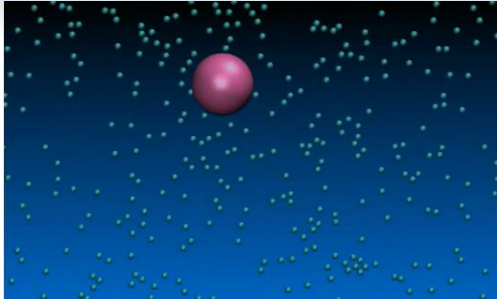

Brownian Motion: Molecular Collisions

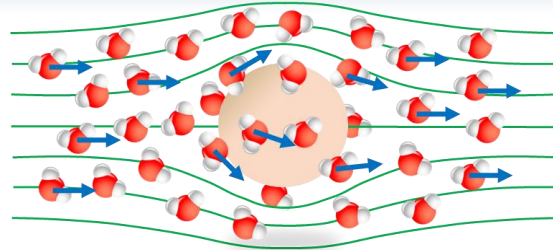

Hydrodynamics + Fluctuations

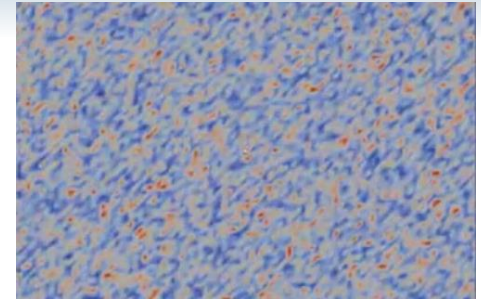

Continuum Gaussian Random Field

Landau-Lifschitz fluctuating hydrodynamics

$$\rho \left(\frac{\partial \mathbf{u}(\mathbf{x}, t)}{\partial t} + \mathbf{u}(\mathbf{x}, t) \cdot \nabla \mathbf{u}(\mathbf{x}, t) \right) = \mu \Delta \mathbf{u}(\mathbf{x}, t) - \nabla p(\mathbf{x}, t) + \nabla \cdot \Sigma(\mathbf{x}, t).$$

$$\nabla \cdot \mathbf{u}(\mathbf{x}, t) = 0.$$

$$\langle \Sigma_{ij}(\mathbf{x}, t) \Sigma_{kl}(\mathbf{y}, s) \rangle = 2\mu k_B T (\delta_{ik} \delta_{jl} + \delta_{il} \delta_{jk}) \delta(\mathbf{x} - \mathbf{y}) \delta(t - s).$$

- Spontaneous momentum transfer from molecular-level interactions.
- Thermal fluctuations captured through random stress Σ .
- Mathematically, equations present challenges since δ -correlation in space-time.
- Fluid-structure interactions?

Immersed Boundary Method

Fluid dynamics

$$\rho \frac{D\mathbf{u}(\mathbf{x}, t)}{Dt} = \mu \Delta \mathbf{u}(\mathbf{x}, t) - \nabla p(\mathbf{x}, t) + \mathbf{F}_{\text{prt}}(\mathbf{x}, t) + \mathbf{F}_{\text{thm}}(\mathbf{x}, t).$$

$$\nabla \cdot \mathbf{u}(\mathbf{x}, t) = 0.$$

Structure dynamics

$$\frac{d\mathbf{X}^{[j]}(t)}{dt} = \int \delta_a(\mathbf{x} - \mathbf{X}^{[j]}(t)) \mathbf{u}(\mathbf{x}, t) d\mathbf{x}$$

$$\mathbf{F}_{\text{ptr}}(\mathbf{x}, t) = \sum_{j=1}^M \mathbf{F}^{[j]} \delta_a(\mathbf{x} - \mathbf{X}^{[j]}(t))$$

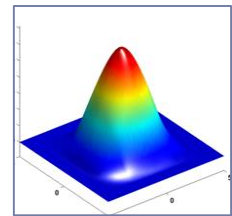
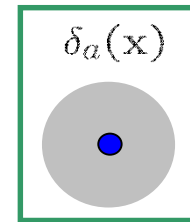
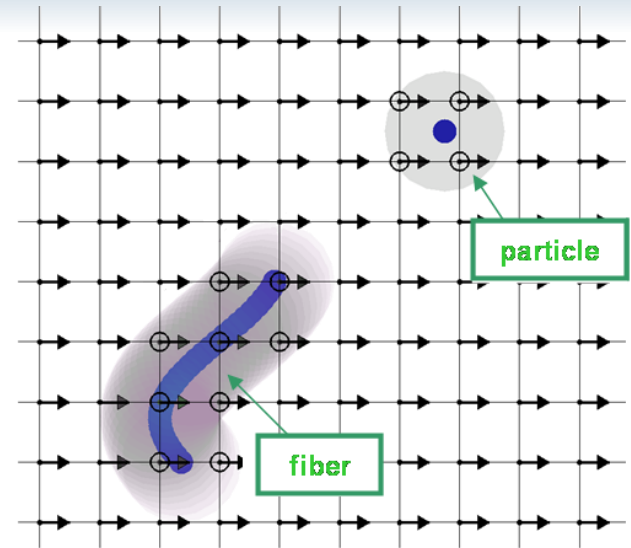

Features:

- Allows conventional discretizations for fluid domain (FV, FFTs).
- Particles, fibers, membranes, and bodies possible.
- Thermal fluctuations: $\mathbf{F}_{\text{thm}} = ?$

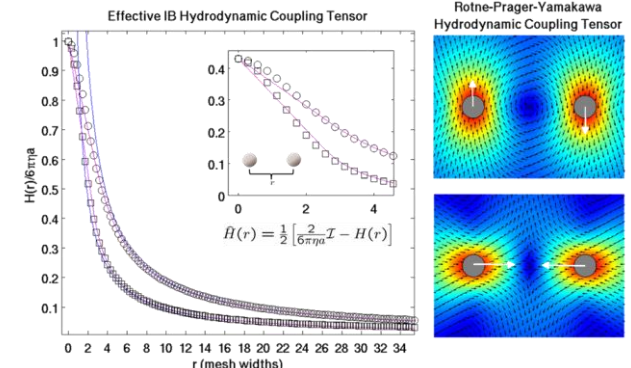

Stochastic Immersed Boundary Method

Fluid-structure equations

$$\rho \frac{D\mathbf{u}(\mathbf{x}, t)}{Dt} = \mu \Delta \mathbf{u}(\mathbf{x}, t) - \nabla p(\mathbf{x}, t) + \mathbf{F}_{\text{prt}}(\mathbf{x}, t) + \mathbf{F}_{\text{thm}}(\mathbf{x}, t).$$

$$\nabla \cdot \mathbf{u}(\mathbf{x}, t) = 0.$$

$$\frac{d\mathbf{X}^{[j]}(t)}{dt} = \int \delta_a(\mathbf{x} - \mathbf{X}^{[j]}(t)) \mathbf{u}(\mathbf{x}, t) d\mathbf{x}$$

$$\mathbf{F}_{\text{prt}}(\mathbf{x}, t) = \sum_{j=1}^M \mathbf{F}^{[j]} \delta_a(\mathbf{x} - \mathbf{X}^{[j]}(t))$$

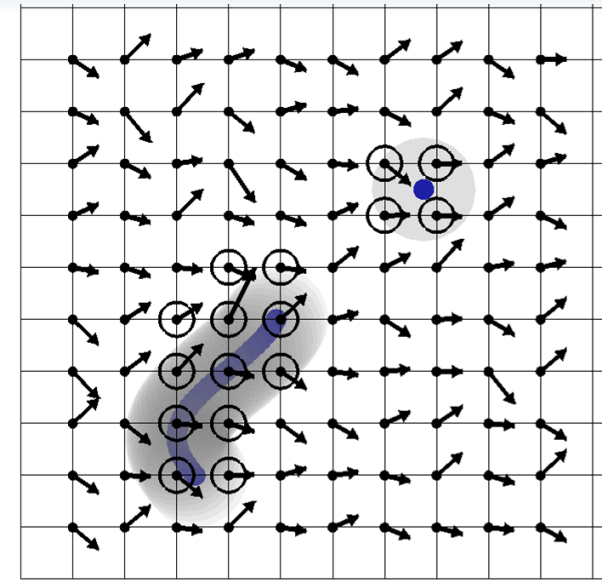

Thermal fluctuations

$$\mathbf{F}_{\text{thm}}(\mathbf{x}, t) = \mathbf{F}_{\text{drift}}(\mathbf{x}, t) + \mathbf{F}_{\text{stoch}}(\mathbf{x}, t)$$

$$\mathbf{F}_{\text{drift}} = -k_B T \sum_{j=1}^M \nabla_{\mathbf{X}^{[j]}} \delta_a(\mathbf{x} - \mathbf{X}^{[j]}(t))$$

$$\langle \mathbf{F}_{\text{stoch}}(\mathbf{x}, t) \mathbf{F}_{\text{stoch}}^T(\mathbf{y}, s) \rangle = -2k_B T \mu \Delta \delta(\mathbf{x} - \mathbf{y}) \delta(t - s)$$

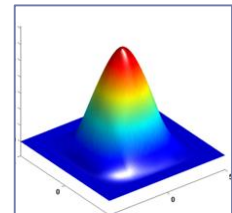
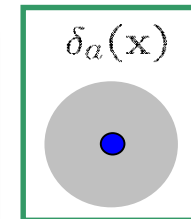

Numerical Approximation

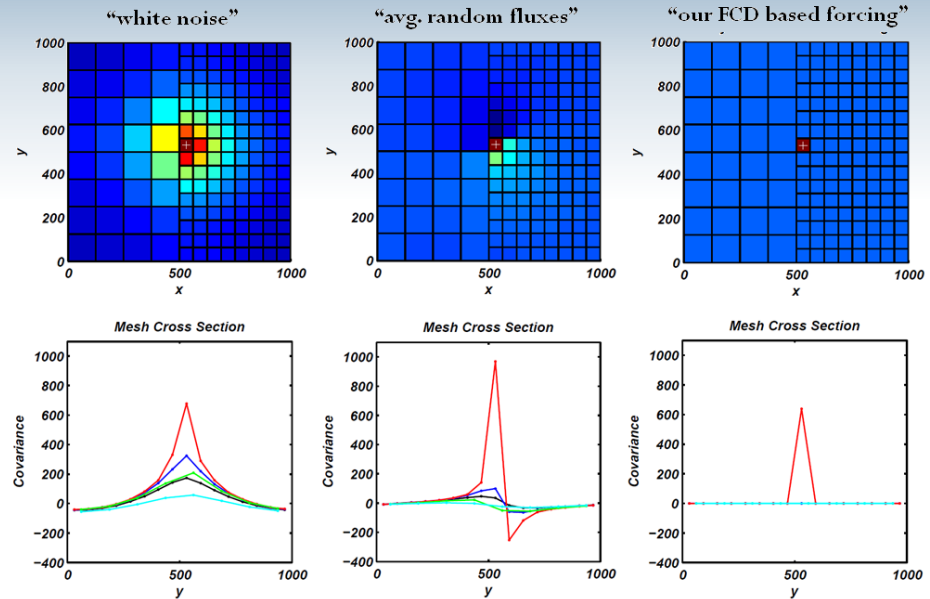
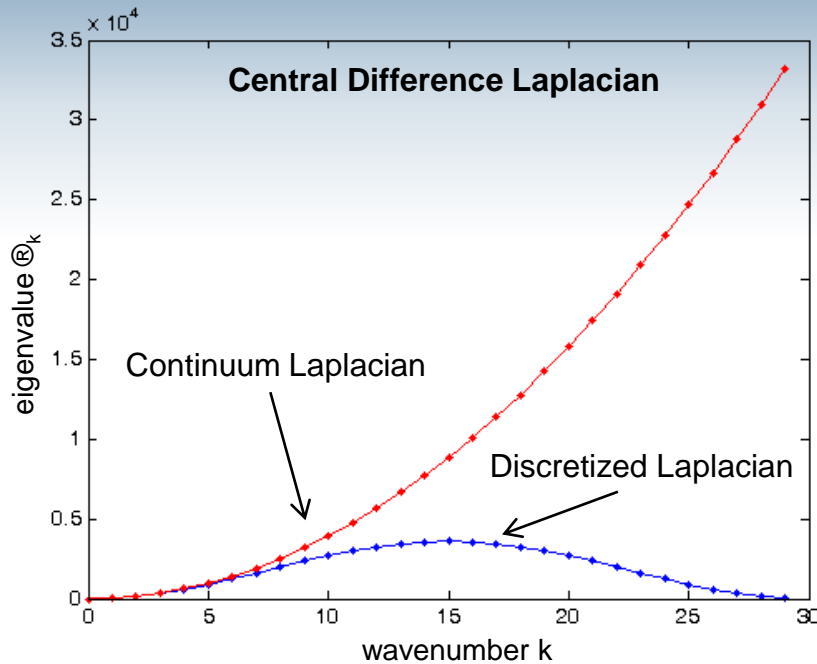

Dissipation rates are different for continuum and discrete system

- Must approximate differently thermal fluctuations in design of numerical methods.
- Mathematical formulation (Atzberger, Kramer, Peskin 2007, Atzberger 2011):
 - Fluctuation-dissipation balance (ito calculus, nyquist relations).
 - Invariance of Gibbs-Boltzmann (kolomogorov pde's, detailed balance)

Fluctuation-dissipation balance condition

$$\langle \mathbf{f}_{\text{thm}}(s) \mathbf{f}_{\text{thm}}^T(t) \rangle = - (LC + CL^T) \delta(t - s)$$

$$L\mathbf{u} \leftarrow \mu \Delta \mathbf{u} \quad C_{ij} \leftarrow \frac{k_B T}{\rho \Delta x^3} \delta_{ij}$$

Numerical Stiffness

Time-scales	
Fluid Modes	Particle Diffusion
$\tau_\lambda = \frac{\rho}{4\pi^2\mu} \lambda^2$	$\tau_{\text{diff}}(a) \approx \frac{a^2}{D_a}$
$\lambda = 10\text{nm} : \tau = 10^{-3}\text{ns}$	$\tau_{\text{diff}}(1\text{nm}) \approx 10^0\text{ns}$
$\lambda = 1000\text{nm} : \tau = 10\text{ns}$	$\tau_{\text{diff}}(10\text{nm}) \approx 10^3\text{ns}$

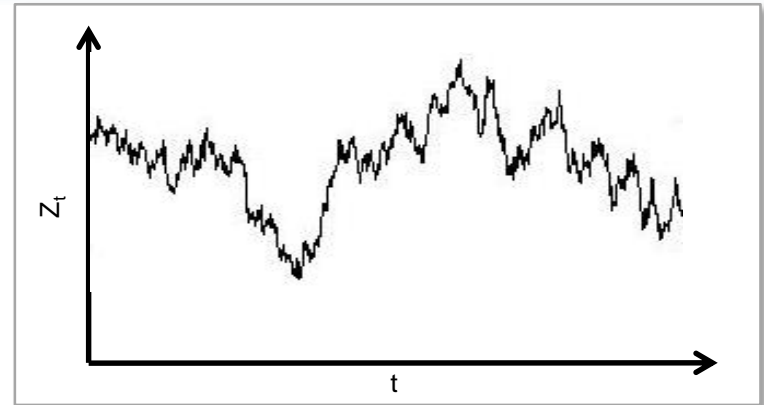

Sources of stiffness

- Fluid-structure have stochastic trajectories.
- Thermal fluctuations excite all fluid modes.
- Length-scales of microstructure involve fluid dynamics at small $Re \ll 1$.
- Equilibration relaxation time-scales of system.
- Elasticity of microstructures.

Two approaches

- Develop stiff stochastic time-step integrators.
- Perturbation analysis of SPDEs : reduced descriptions.

Stiff Time-step Integrator

Fluid equations

$$d\mathbf{u} = \mathcal{L}\mathbf{u}dt \quad (\text{viscous damping})$$

$$+ \rho^{-1}\mathbf{F}_{\text{prt}}dt \quad (\text{particle force})$$

$$+ Qd\mathbf{B}_t \quad (\text{thermal force})$$

$$\nabla \cdot \mathbf{u} = 0 \quad (\text{incompressibility})$$

Structure equations

$$\frac{d\mathbf{X}^{[j]}(t)}{dt} = \int \delta_a(\mathbf{x} - \mathbf{X}^{[j]}(t))\mathbf{u}(\mathbf{x}, t)d\mathbf{x}$$

$$\mathbf{F}_{\text{prt}}(\mathbf{x}, t) = \sum_{j=1}^M -\nabla_{\mathbf{X}^{[j]}}V(\{\mathbf{X}(t)\})\delta_a(\mathbf{x} - \mathbf{X}^{[j]}(t))$$

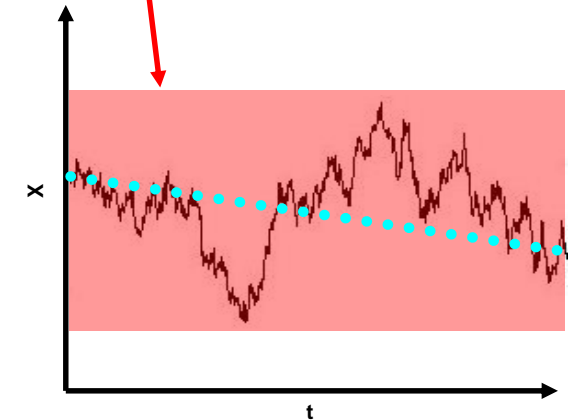
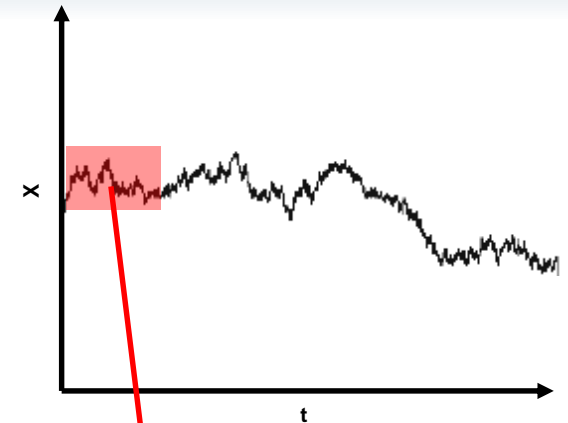

Integration by exponential factor (ito calculus)

$$= e^{t\mathcal{L}}\mathbf{u}(0) + \int_0^t e^{(t-s)\mathcal{L}}\rho^{-1}\mathbf{F}_{\text{prt}}(s)ds + \int_0^t e^{(t-s)\mathcal{L}}Qd\mathbf{B}_s = e^{t\mathcal{L}}\mathbf{u}(0) + \bar{\mathbf{I}}_{\text{prt}} + \bar{\mathbf{I}}_{\text{thm}}$$

Stiff Time-step Integrator

Integration by exponential factor (ito calculus)

$$\mathbf{u}(t) = e^{t\mathcal{L}}\mathbf{u}(0) + \int_0^t e^{(t-s)\mathcal{L}}\rho^{-1}\mathbf{F}_{\text{prt}}(s)ds + \int_0^t e^{(t-s)\mathcal{L}}Qd\mathbf{B}_s = e^{t\mathcal{L}}\mathbf{u}(0) + \bar{\mathbf{I}}_{\text{prt}} + \bar{\mathbf{I}}_{\text{thm}}$$

Particle force

$$\mathbf{I}_{\text{prt}}(t) := \int_0^t e^{(t-s)\mathcal{L}}\rho^{-1}\mathbf{F}_{\text{prt}}(s)ds$$

Approximate by constant force

$$\hookrightarrow \mathbf{I}_{\text{prt}}(t) \approx -\rho^{-1}\mathcal{L}^{-1} [\mathcal{I} - e^{t\mathcal{L}}] \mathbf{F}_{\text{prt}}(0)$$

Thermal fluctuations

$$\mathbf{I}_{\text{thm}}(t) := \int_0^t e^{(t-s)\mathcal{L}}Qd\mathbf{B}_s$$

Ito calculus yields Gaussian with

$$\begin{aligned} \hookrightarrow \langle \mathbf{I}_{\text{thm}}(t) \rangle &= 0 \\ \langle \mathbf{I}_{\text{thm}}(t)\mathbf{I}_{\text{thm}}(t)^T \rangle &= \int_0^t e^{(t-s)\mathcal{L}}QQ^T e^{(t-s)\mathcal{L}^T} ds := \Lambda(t) \\ \Lambda_{\mathbf{k},\mathbf{k}}(t) &= -\frac{1}{2\alpha_{\mathbf{k}}} [1 - e^{-2\alpha_{\mathbf{k}}\Delta t}] Q_{\mathbf{k},\mathbf{k}}^2 \end{aligned}$$

Stiff Time-step Integrator

Integration by exponential factor (ito calculus)

$$\mathbf{u}(t) = e^{t\mathcal{L}}\mathbf{u}(0) + \int_0^t e^{(t-s)\mathcal{L}}\rho^{-1}\mathbf{F}_{\text{prt}}(s)ds + \int_0^t e^{(t-s)\mathcal{L}}Qd\mathbf{B}_s = e^{t\mathcal{L}}\mathbf{u}(0) + \bar{\mathbf{I}}_{\text{prt}} + \bar{\mathbf{I}}_{\text{thm}}$$

$$\mathbf{I}_{\text{prt}}(t) \approx -\rho^{-1}\mathcal{L}^{-1}[\mathcal{I} - e^{t\mathcal{L}}]\mathbf{F}_{\text{prt}}(0)$$

$$\Lambda_{\mathbf{k},\mathbf{k}}(t) = -\frac{1}{2\alpha_{\mathbf{k}}}[1 - e^{-2\alpha_{\mathbf{k}}\Delta t}]Q_{\mathbf{k},\mathbf{k}}^2$$

Fluid Integrator

$$\mathbf{u}^{n+1} = e^{\Delta t\mathcal{L}}\mathbf{u}^n + \mathcal{L}^{-1}[\mathcal{I} - e^{\Delta t\mathcal{L}}]\rho^{-1}\mathbf{F}_{\text{prt}}^n + \Gamma\xi^n$$

ξ is Gaussian with

$$\langle \xi \rangle = 0, \quad \langle \xi\xi^T \rangle = \mathcal{I}$$

$$\Lambda = \Gamma\Gamma^T$$

- unconditionally stable.
- accuracy depends only on structure force approximation (otherwise exact).
- requires prior knowledge of Γ .
- method **viable only** if efficient to compute $e^{\Delta t\mathcal{L}}$.
- viable for uniform meshes (FFTs).

Stiff Time-step Integrator

Fluid equations

$$d\mathbf{u} = \mathcal{L}\mathbf{u}dt \quad (\text{viscous damping})$$

$$+ \rho^{-1}\mathbf{F}_{\text{prt}}dt \quad (\text{particle force})$$

$$+ Qd\mathbf{B}_t \quad (\text{thermal force})$$

$$\nabla \cdot \mathbf{u} = 0 \quad (\text{incompressibility})$$

Structure equations

$$\frac{d\mathbf{X}^{[j]}(t)}{dt} = \int \delta_a(\mathbf{x} - \mathbf{X}^{[j]}(t))\mathbf{u}(\mathbf{x}, t)d\mathbf{x}$$

$$\mathbf{F}_{\text{prt}}(\mathbf{x}, t) = \sum_{j=1}^M -\nabla_{\mathbf{X}^{[j]}}V(\{\mathbf{X}(t)\})\delta_a(\mathbf{x} - \mathbf{X}^{[j]}(t))$$

Integrate structure dynamics (ito calculus)

$$\mathbf{X}^{[j]}(t) = \mathbf{X}^{[j]}(0) + \int_0^t \int \delta_a(\mathbf{x} - \mathbf{X}^{[j]}(s))\mathbf{u}(\mathbf{x}, s)d\mathbf{x}ds \approx \mathbf{X}^{[j]}(0) + \int \delta_a(\mathbf{x} - \mathbf{X}^{[j]}(0)) \int_0^t \mathbf{u}(\mathbf{x}, s)d\mathbf{x}ds$$

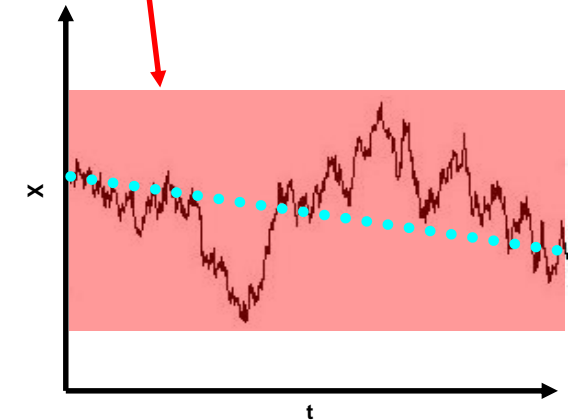
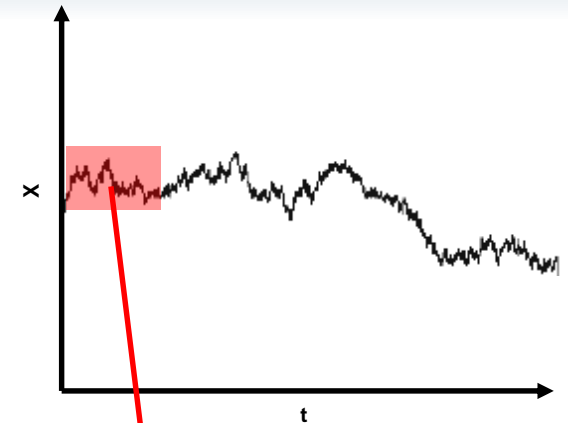

Stiff Time-step Integrator

Integrate structure dynamics (ito calculus)

$$\mathbf{X}^{[j]}(t) \approx \mathbf{X}^{[j]}(0) + \int_0^t \delta_a(\mathbf{x} - \mathbf{X}^{[j]}(0)) \int_0^t \mathbf{u}(\mathbf{x}, s) ds d\mathbf{x}$$
$$\hookrightarrow \mathbf{X}^{[j],n+1} = \mathbf{X}^{[j],n} + \int \delta_a(\mathbf{x} - \mathbf{X}^{[j],n}) \mathbf{I}_{\text{vel}}(\mathbf{x}, \Delta t) d\mathbf{x}$$
$$\mathbf{I}_{\text{vel}}(t) := \int_0^t \mathbf{u}(s) ds$$

Integrated fluctuating fluid velocity

$\mathbf{I}_{\text{vel}}(t)$ is a Gaussian with

$$\bar{\mathbf{I}}_{\text{vel}} := \langle \mathbf{I}_{\text{vel}}(t) \rangle = \int_0^t \langle \mathbf{u}(s) \rangle ds = -\mathcal{L}^{-1} [\mathcal{I} - e^{t\mathcal{L}}] \mathbf{u}(0) + -\mathcal{L}^{-1} [t + \mathcal{L}^{-1} [\mathcal{I} - e^{t\mathcal{L}}]] \mathbf{F}_{\text{prt}}(0)$$

$$\Phi := \langle (\mathbf{I}_{\text{vel}}(t) - \bar{\mathbf{I}}_{\text{vel}}(t)) (\mathbf{I}_{\text{vel}}^T(t) - \bar{\mathbf{I}}_{\text{vel}}^T(t)) \rangle = \int_0^t \int_0^t e^{r\mathcal{L}} C e^{s\mathcal{L}^T} dr ds + \int_0^t \int_0^t \int_0^{s \wedge r} e^{(r-w)\mathcal{L}} Q Q^T e^{(s-w)\mathcal{L}^T} dw dr ds$$

$\mathbf{I}_{\text{vel}}(t)$ is correlated with $\mathbf{I}_{\text{thm}}(t)$

$$W := \langle (\mathbf{I}_{\text{vel}}(t) - \bar{\mathbf{I}}_{\text{vel}}(t)) \mathbf{I}_{\text{thm}}^T(t) \rangle = \mathcal{L}^{-1} \int_0^t e^{(t-w)\mathcal{L}} Q Q^T e^{(t-w)\mathcal{L}^T} dw + \mathcal{L}^{-1} Q Q^T \mathcal{L}^{-T} [\mathcal{I} - e^{t\mathcal{L}^T}]$$

Structure Integrator

$$\mathbf{X}^{[j],n+1} = \mathbf{X}^{[j],n} + \int \delta_a(\mathbf{x} - \mathbf{X}^{[j],n}) \mathbf{I}_{\text{vel}}(\mathbf{x}, \Delta t) d\mathbf{x}$$

- stability depends now on structure forces.
- accuracy depends on
 - fluid sampling approximation $\mathbf{X}(t) \sim \mathbf{X}(0)$ and structure force approximation.
- method **viable only** if efficient to compute exponentials.
- viable for uniform meshes (FFTs).

Summary : Stiff Integrator

Fluid Integrator

$$\mathbf{u}^{n+1} = e^{\Delta t \mathcal{L}} \mathbf{u}^n + \mathcal{L}^{-1} [\mathcal{I} - e^{\Delta t \mathcal{L}}] \rho^{-1} \mathbf{F}_{\text{prt}}^n + \Gamma \xi^n$$

ξ is Gaussian with

$$\langle \xi \rangle = 0, \quad \langle \xi \xi^T \rangle = \mathcal{I}$$

$$\Lambda = \Gamma \Gamma^T$$

Structure Integrator

$$\mathbf{X}^{[j],n+1} = \mathbf{X}^{[j],n} + \int \delta_a(\mathbf{x} - \mathbf{X}^{[j],n}) \mathbf{I}_{\text{vel}}(\mathbf{x}, \Delta t) d\mathbf{x}$$

$\mathbf{I}_{\text{vel}}(t)$ is a Gaussian with

$$\bar{\mathbf{I}}_{\text{vel}} := \langle \mathbf{I}_{\text{vel}}(t) \rangle = \int_0^t \langle \mathbf{u}(s) \rangle ds = -\mathcal{L}^{-1} [\mathcal{I} - e^{t\mathcal{L}}] \mathbf{u}(0) + -\mathcal{L}^{-1} [t + \mathcal{L}^{-1} [\mathcal{I} - e^{t\mathcal{L}}]] \mathbf{F}_{\text{prt}}(0)$$

$$\Phi := \langle (\mathbf{I}_{\text{vel}}(t) - \bar{\mathbf{I}}_{\text{vel}}(t)) (\mathbf{I}_{\text{vel}}^T(t) - \bar{\mathbf{I}}_{\text{vel}}^T(t)) \rangle = \int_0^t \int_0^t e^{r\mathcal{L}} C e^{s\mathcal{L}^T} dr ds + \int_0^t \int_0^t \int_0^{s \wedge r} e^{(r-w)\mathcal{L}} Q Q^T e^{(s-w)\mathcal{L}^T} dw dr ds$$

$\mathbf{I}_{\text{vel}}(t)$ is correlated with $\mathbf{I}_{\text{thm}}(t)$

$$W := \langle (\mathbf{I}_{\text{vel}}(t) - \bar{\mathbf{I}}_{\text{vel}}(t)) \mathbf{I}_{\text{thm}}^T(t) \rangle = \mathcal{L}^{-1} \int_0^t e^{(t-w)\mathcal{L}} Q Q^T e^{(t-w)\mathcal{L}^T} dw + \mathcal{L}^{-1} Q Q^T \mathcal{L}^{-T} [\mathcal{I} - e^{t\mathcal{L}^T}]$$

- method **viable only if** efficient to compute exponentials.
- viable for uniform meshes (FFTs).
- under-resolves fluid mode dynamics and fluctuations.
- time-step limited by structure's motions.

Validation of Numerical Methods

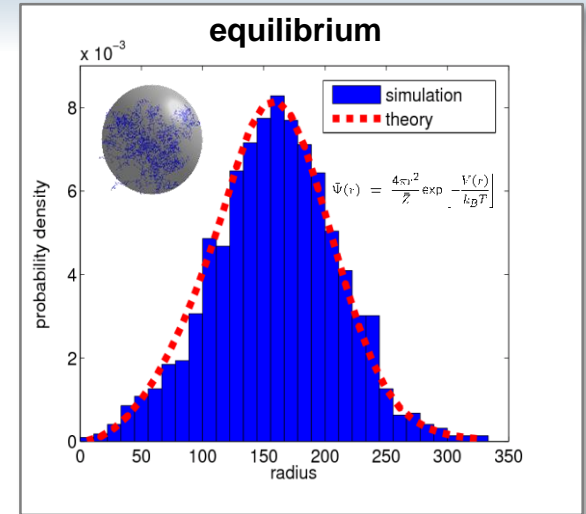
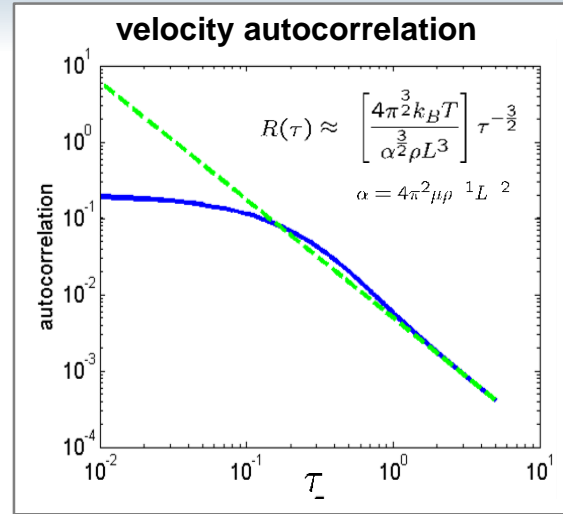
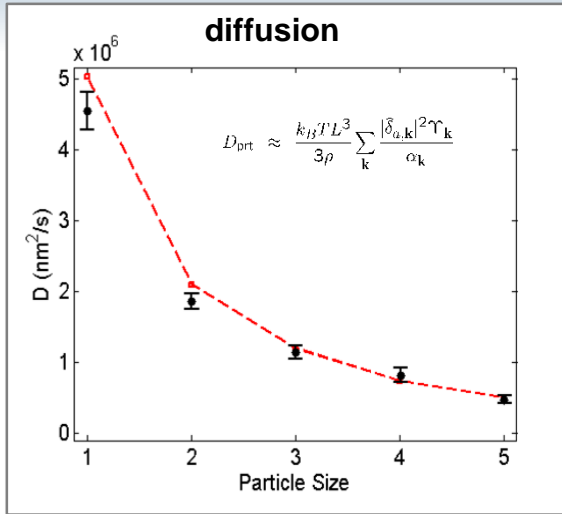

Validation

- Diffusivity of under-resolved particles correct.
- Velocity auto-correlation has $t^{-3/2}$ tail (Adler & Wainright 1950),
- Auto-correlation persists from hydrodynamic “memory.”
- Equilibrium configurations have Gibbs-Boltzmann statistics.
- Can ideas be extended to other coupling types and regimes?

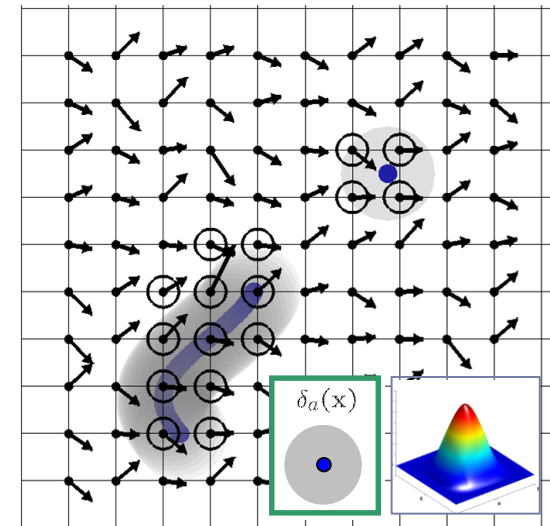

Generalization : Stochastic Eulerian Lagrangian Methods

Fluid

$$\rho \frac{\partial \mathbf{u}}{\partial t} = \mathcal{L} \mathbf{u} + \Lambda [\Upsilon (\mathbf{v} - \Gamma \mathbf{u})] + \lambda + \mathbf{f}_{\text{thm}}$$

$$\nabla \cdot \mathbf{u} = 0$$

Structure

$$\frac{d\mathbf{X}}{dt} = \mathbf{v}$$

$$m \frac{d\mathbf{v}}{dt} = -\Upsilon (\mathbf{v} - \Gamma \mathbf{u}) - \nabla_{\mathbf{X}} \Phi[\mathbf{X}] + \zeta + \mathbf{F}_{\text{thm}}$$

Thermal fluctuations

$$\langle \mathbf{f}_{\text{thm}}(s) \mathbf{f}_{\text{thm}}^T(t) \rangle = -(2k_B T) (\mathcal{L} - \Lambda \Upsilon \Gamma) \delta(t - s)$$

$$\langle \mathbf{F}_{\text{thm}}(s) \mathbf{F}_{\text{thm}}^T(t) \rangle = (2k_B T) \Upsilon \delta(t - s)$$

$$\langle \mathbf{f}_{\text{thm}}(s) \mathbf{F}_{\text{thm}}^T(t) \rangle = -(2k_B T) \Lambda \Upsilon \delta(t - s).$$

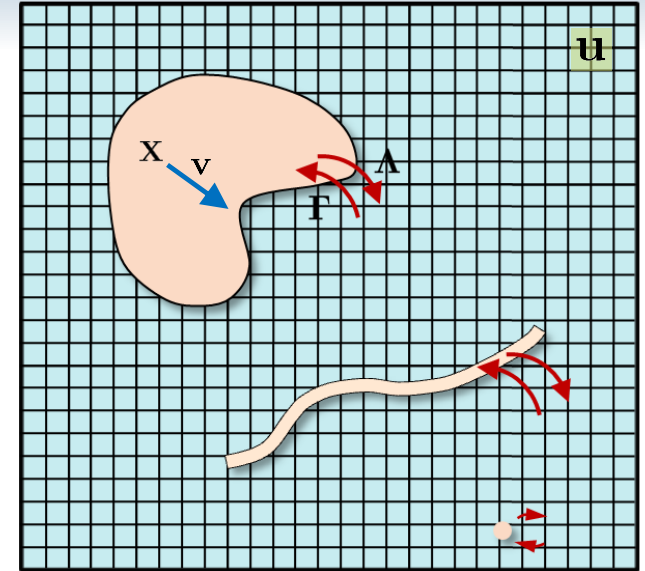

Operators:

- $\mathcal{L} \longrightarrow$ Fluid dissipation (viscosity).
- $\Upsilon \longrightarrow$ Structure "slip" relative to local flow field.
- $\Gamma \longrightarrow$ Kinematic particle velocity for given flow.
- $\Lambda \longrightarrow$ Induced fluid force density from particle.

Notation:

- $\mathbf{u} = \mathbf{u}(\mathbf{x}, t) \longrightarrow$ Fluid velocity.
- $\mathbf{X} = \mathbf{X}(\mathbf{q}, t) \longrightarrow$ Structure configuration
- $\mathbf{v} = \mathbf{v}(\mathbf{q}, t) \longrightarrow$ Structure velocity.

Coupling Operators

Conservation of momentum

$$\int_{\Omega} (\Lambda \mathbf{F})(\mathbf{x}) d\mathbf{x} = \int_{\mathcal{S}} \mathbf{F}(\mathbf{q}) d\mathbf{q}$$

└──→ “integrates to one.”

Conservation of energy

(overdamped limit)

$$E[\mathbf{u}, \mathbf{X}] = \frac{1}{2} \int \rho |\mathbf{u}(\mathbf{y})|^2 d\mathbf{y} + \Phi(\mathbf{X})$$

Adjoint condition

$$\int_{\mathcal{S}} (\Gamma \mathbf{u})(\mathbf{q}) \cdot \mathbf{F}(\mathbf{q}) d\mathbf{q} = \int_{\Omega} \mathbf{u}(\mathbf{x}) \cdot (\Lambda \mathbf{F})(\mathbf{x}) d\mathbf{x}$$

└──→ $\langle \Gamma \mathbf{u}, \mathbf{F} \rangle = \langle \mathbf{u}, \Lambda \mathbf{F} \rangle \longrightarrow \text{“}\Gamma = \Lambda^T\text{”}$

- Energy conserved → coupling operators are **adjoints!**
- Useful for **deriving coupling operators.**

Immersed Boundary Method

Coupling operators

$$\Gamma[u] = \int \delta_a(\mathbf{x} - \mathbf{X}^{[j]}(t)) \mathbf{u}(\mathbf{x}, t) d\mathbf{x}$$

$$\Lambda[F] = \delta_a(\mathbf{x} - \mathbf{X}^{[j]}(t)) \mathbf{F}$$

$$\text{“}\Gamma = \Lambda^T\text{”}$$

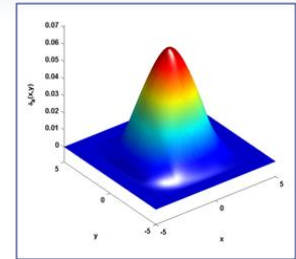
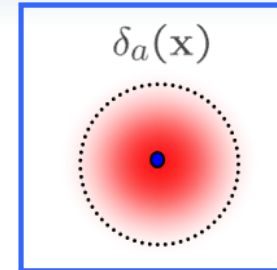

Peskin delta-function

Effective IB Hydrodynamic Coupling Tensor

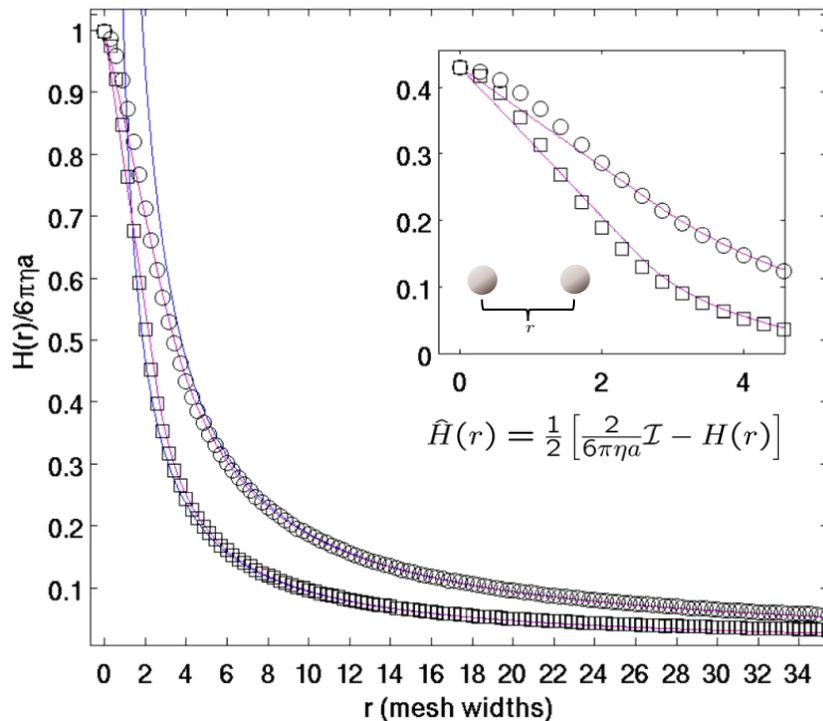

Rotne-Prager-Yamakawa
Hydrodynamic Coupling Tensor

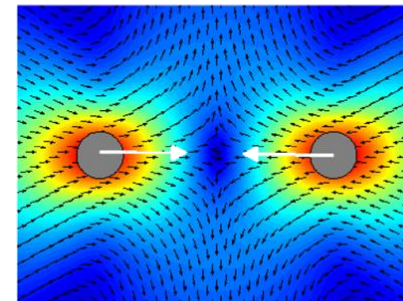
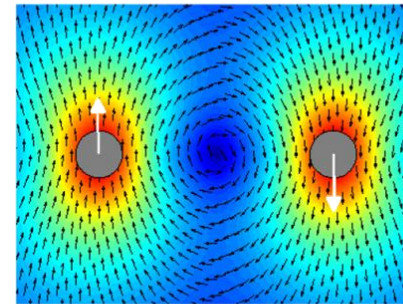

Coupling Operators based on Faxen Relations

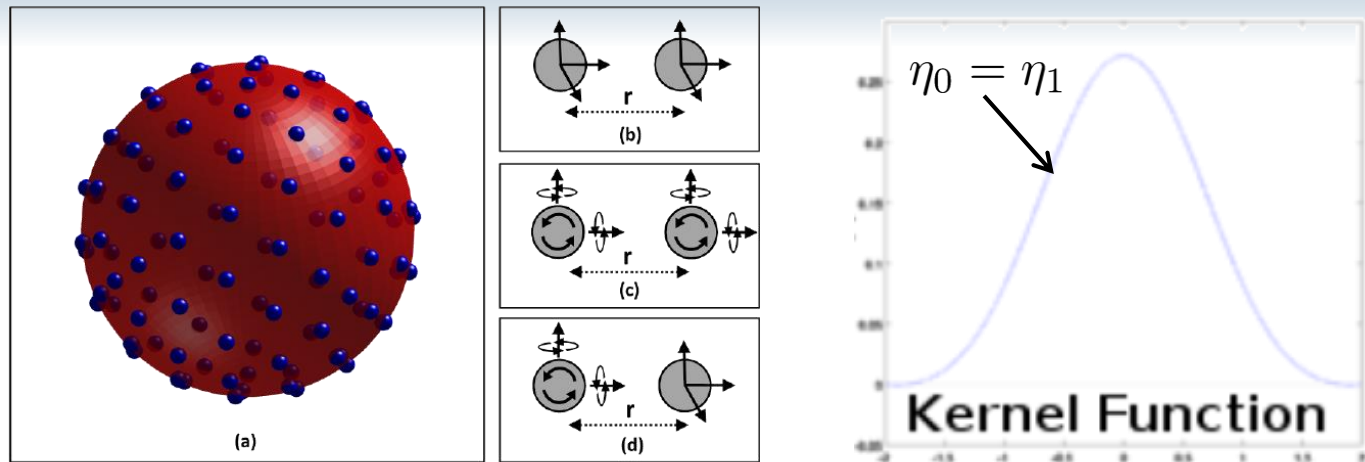

Faxen Kinematic Relations $\rightarrow \Gamma$:

$$\Gamma_0 \mathbf{u} = \sum_{\mathbf{m}} \langle \eta_0(\mathbf{y}_{\mathbf{m}} - (\mathbf{X}_{\text{cm}} + \mathbf{z})) \mathbf{u}_{\mathbf{m}} \rangle_{\tilde{\mathcal{S}}, |\mathbf{z}|=R} \Delta x_{\mathbf{m}}^3$$

$$\Gamma_1 \mathbf{u} = \frac{3}{2R^2} \sum_{\mathbf{m}} \langle \eta_1(\mathbf{y}_{\mathbf{m}} - (\mathbf{X}_{\text{cm}} + \mathbf{z})) (\mathbf{z} \times \mathbf{u}_{\mathbf{m}}) \rangle_{\tilde{\mathcal{S}}, |\mathbf{z}|=R} \Delta x_{\mathbf{m}}^3.$$

Adjoint Condition $\rightarrow \Lambda$:

$$\Lambda_0(\mathbf{x}_{\mathbf{m}}) = \left(\langle \eta_0(\mathbf{x}_{\mathbf{m}} - (\mathbf{X}_{\text{cm}} + \mathbf{z})) \rangle_{\tilde{\mathcal{S}}, |\mathbf{z}|=R} \right) \mathbf{F}$$

$$\Lambda_1(\mathbf{x}_{\mathbf{m}}) = -\frac{3}{2R^2} \left(\langle \mathbf{z} \eta_1(\mathbf{x}_{\mathbf{m}} - (\mathbf{X}_{\text{cm}} + \mathbf{z})) \rangle_{\tilde{\mathcal{S}}, |\mathbf{z}|=R} \right) \times \mathbf{T}.$$

Coupling Operators based on Faxen Relations

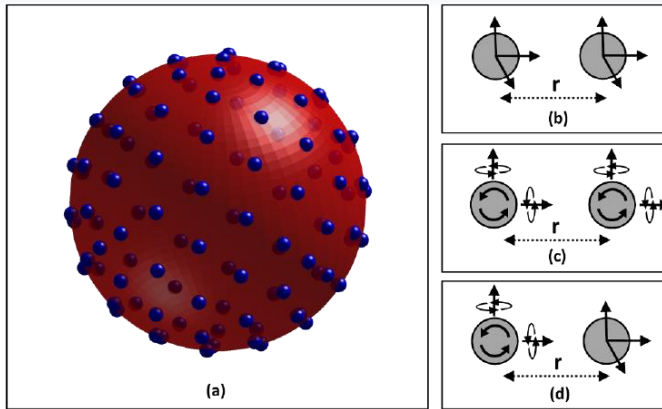

(Translation-Translation)

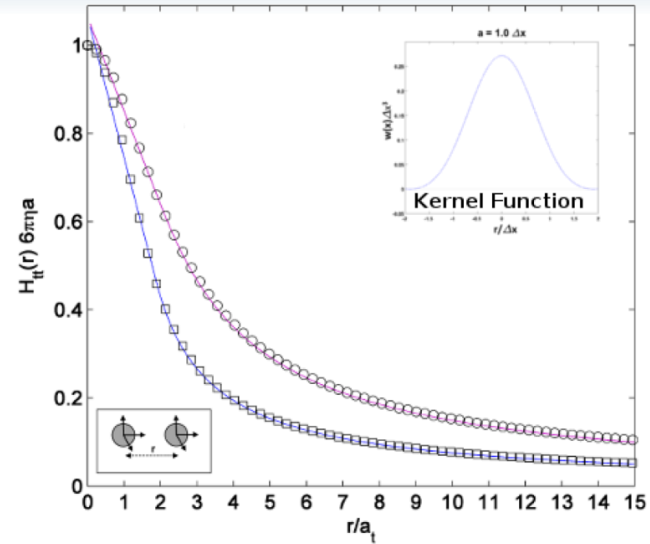

(Rotation-Rotation)

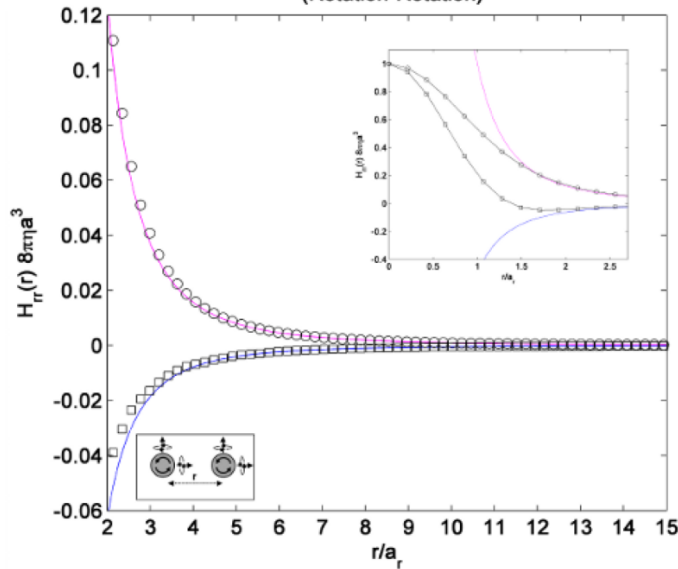

(Rotation-Translation)

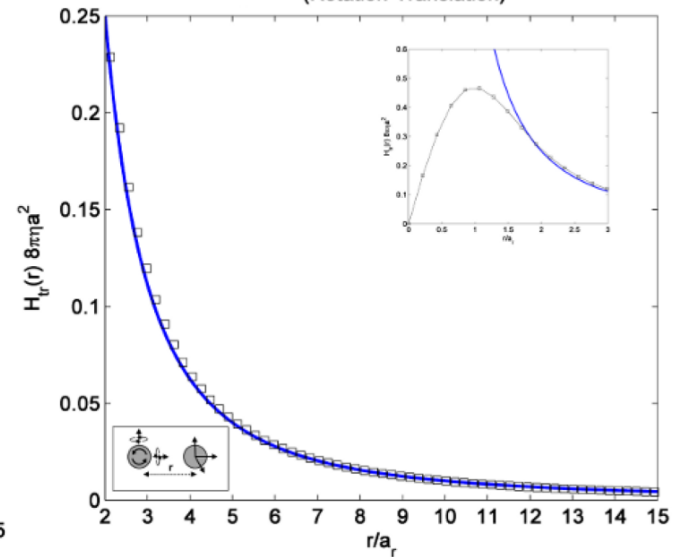

Excellent agreement for $r > 2a$!

Numerical Stiffness

Time-scales	
Fluid Modes	Particle Diffusion
$\tau_\lambda = \frac{\rho}{4\pi^2\mu} \lambda^2$	$\tau_{\text{diff}}(a) \approx \frac{a^2}{D_a}$
$\lambda = 10\text{nm} : \tau = 10^{-3}\text{ns}$	$\tau_{\text{diff}}(1\text{nm}) \approx 10^0\text{ns}$
$\lambda = 1000\text{nm} : \tau = 10\text{ns}$	$\tau_{\text{diff}}(10\text{nm}) \approx 10^3\text{ns}$

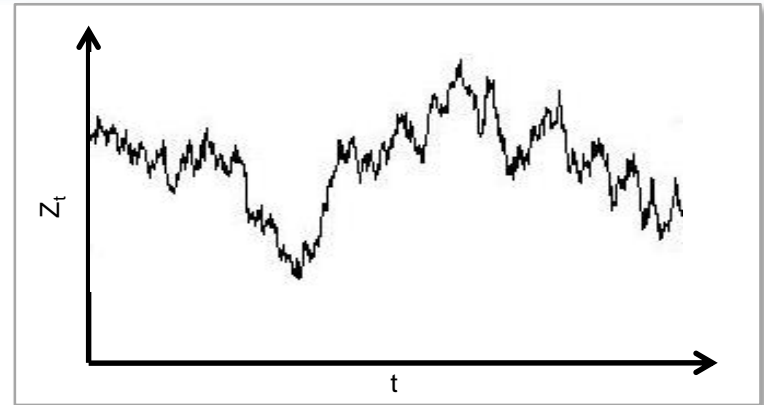

Sources of stiffness

- In SELM additional sources of stiffness from
 - microstructure inertia
 - fluid-structure slip $-\Upsilon(\mathbf{v} - \Gamma\mathbf{u})$
- Thermal fluctuations also excite coupling modes and all fluid modes.
- Elasticity of microstructures.
- Equilibration time-scales of system vary over wide range.

Two approaches

- Develop stiff stochastic time-step integrators (as for SIBM).
- Perturbation analysis of SPDEs : reduced descriptions.

Stochastic Reduction

Stochastic differential equation:

$$d\mathbf{Z}(t) = \mathbf{a}(\mathbf{Z}(t))dt + \mathbf{b}(\mathbf{Z}(t))d\mathbf{W}_t \longrightarrow L_\epsilon = \mathbf{a} \cdot \frac{\partial}{\partial \mathbf{z}} + \frac{1}{2} \mathbf{b}\mathbf{b}^T : \frac{\partial^2}{\partial \mathbf{z}^2}$$

Backward-Kolomogorov PDE:

$$\begin{aligned} \frac{\partial u}{\partial t} &= L_\epsilon u \\ u(x, 0) &= f(x) \end{aligned} \longrightarrow u(x, t) = E^{x,0} [f(X_t)]$$

Perturbation Analysis:

$$u(\mathbf{z}, t) = u_0(\mathbf{z}, t) + u_1(\mathbf{z}, t)\epsilon + u_2(\mathbf{z}, t)\epsilon^2 \cdots + u_n(\mathbf{z}, t)\epsilon^n + \cdots$$

Split operator into “slow” and “fast” parts:

$$L_\epsilon = \epsilon^{-1}L_1 + \epsilon^{-2}L_{fast}$$

↓ $\epsilon \rightarrow 0$: compare orders

$$L_0 = -\left[\int_{\mathbb{R}^N} \psi L_1 L_{fast}^{-1} L_1 d\mathbf{v}\right] \text{ leading order dynamics.}$$

Reduced dynamics:

$$L_0 = \tilde{\mathbf{a}} \cdot \frac{\partial}{\partial \mathbf{z}} + \frac{1}{2} \tilde{\mathbf{b}}\tilde{\mathbf{b}}^T : \frac{\partial^2}{\partial \mathbf{z}^2} \longrightarrow d\tilde{\mathbf{Z}}_t = \tilde{\mathbf{a}}(\tilde{\mathbf{Z}}_t)dt + \tilde{\mathbf{b}}(\tilde{\mathbf{Z}}_t)d\tilde{\mathbf{W}}_t$$

Summary of regimes

Stochastic Eulerian Lagrangian Method (SELM)

Fluid dynamics:

$$\rho \frac{\partial \mathbf{u}}{\partial t} = \mu \Delta \mathbf{u} - \nabla p + \Lambda [\Upsilon (\mathbf{v} - \Gamma \mathbf{u})] + \mathbf{f}_{\text{thm}}$$

$$\nabla \cdot \mathbf{u} = 0$$

Structure dynamics:

$$\frac{d\mathbf{X}}{dt} = \mathbf{v}$$

$$m \frac{d\mathbf{v}}{dt} = -\Upsilon (\mathbf{v} - \Gamma \mathbf{u}) - \nabla_{\mathbf{X}} \Phi[\mathbf{X}] + \zeta + \mathbf{F}_{\text{thm}}$$

Thermal Fluctuations

$$\langle \mathbf{f}_{\text{thm}}(s) \mathbf{f}_{\text{thm}}^T(t) \rangle = -(2k_B T) (\mu \Delta - \Lambda \Upsilon \Gamma) \delta(t-s)$$

$$\langle \mathbf{F}_{\text{thm}}(s) \mathbf{F}_{\text{thm}}^T(t) \rangle = (2k_B T) \Upsilon \delta(t-s)$$

$$\langle \mathbf{f}_{\text{thm}}(s) \mathbf{F}_{\text{thm}}^T(t) \rangle = -(2k_B T) \Lambda \Upsilon \delta(t-s).$$

Microstructure density matched with fluid

$$m \ll \rho \ell^3$$

Fluid-structure dynamics:

$$\frac{d\mathbf{p}}{dt} = \rho^{-1} \mathcal{L} \mathbf{p} + \Lambda [-\nabla_{\mathbf{X}} \Phi(\mathbf{X})] - (\nabla_{\mathbf{X}} \cdot \Lambda) k_B T + \lambda + \mathbf{g}_{\text{thm}}$$

$$\frac{d\mathbf{X}}{dt} = \rho^{-1} \Gamma \mathbf{p} + \Upsilon^{-1} [-\nabla_{\mathbf{X}} \Phi(\mathbf{X})] + \zeta + \mathbf{G}_{\text{thm}}$$

$$\nabla_{\mathbf{X}} \cdot \Lambda = \text{Tr}[\nabla_{\mathbf{X}} \Lambda]$$

Phase space compressibility (p, X).

Thermal Fluctuations:

$$\langle \mathbf{g}_{\text{thm}}(s) \mathbf{g}_{\text{thm}}^T(t) \rangle = -(2k_B T) \mathcal{L} \delta(t-s)$$

$$\langle \mathbf{G}_{\text{thm}}(s) \mathbf{G}_{\text{thm}}^T(t) \rangle = (2k_B T) \Upsilon^{-1} \delta(t-s)$$

$$\langle \mathbf{g}_{\text{thm}}(s) \mathbf{G}_{\text{thm}}^T(t) \rangle = 0.$$

- Structure momentum no longer tracked.
- Removes a source of stiffness.
- Non-conjugate Hamiltonian formulation yields metric-factor in phase-space.

Microstructure-fluid no-slip coupling (S-Immersed-Boundary)

$$\Upsilon \rightarrow \infty$$

Fluid-Structure Equations:

$$\frac{d\mathbf{p}}{dt} = \rho^{-1} \mathcal{L} \mathbf{p} + \Lambda [-\nabla_{\mathbf{X}} \Phi(\mathbf{X})] + (\nabla_{\mathbf{X}} \cdot \Lambda) k_B T + \lambda + \mathbf{g}_{\text{thm}}$$

$$\frac{d\mathbf{X}}{dt} = \rho^{-1} \Gamma \mathbf{p}$$

Thermal Fluctuations:

$$\langle \mathbf{g}_{\text{thm}}(s) \mathbf{g}_{\text{thm}}^T(t) \rangle = -(2k_B T) \mathcal{L} \delta(t-s).$$

- Structure dynamics no-longer inertial.
- Removes additional sources of stiffness.
- Regime of the Stochastic Immersed Boundary Method.
- Phase-space metric reflected in the drift term.

Microstructure-fluid stress balance

$$\mu \rightarrow \infty$$

Fluid-Structure Equations:

$$\frac{d\mathbf{X}}{dt} = H_{\text{SELM}} [-\nabla_{\mathbf{X}} \Phi(\mathbf{X})] + (\nabla_{\mathbf{X}} \cdot H_{\text{SELM}}) k_B T + \mathbf{h}_{\text{thm}}$$

$$H_{\text{SELM}} = \Gamma (-\wp \mathcal{L})^{-1} \Lambda$$

Thermal Fluctuations:

$$\langle \mathbf{h}_{\text{thm}}(s) \mathbf{h}_{\text{thm}}^T(t) \rangle = (2k_B T) H_{\text{SELM}} \delta(t-s).$$

- Fluid momentum no longer tracked.
- Balance of hydrodynamic stresses with elastic stresses.
- Removes additional sources of stiffness.
- Regime of the Stokesian-Brownian Dynamics (Brady 1980, McCammond 1980's).
- Phase-space metric reflected in the drift term.

Adaptive Meshes

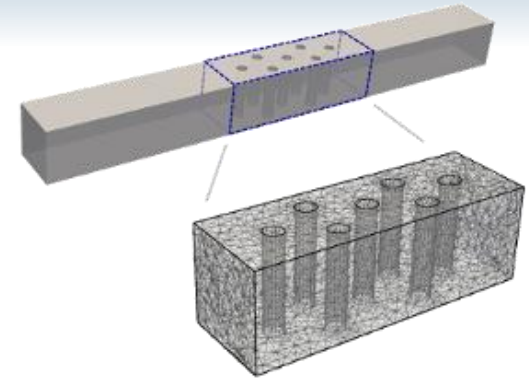
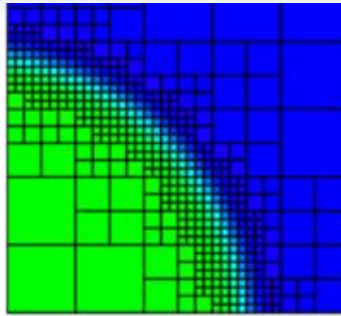
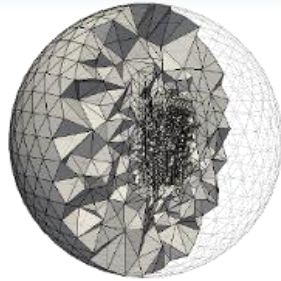
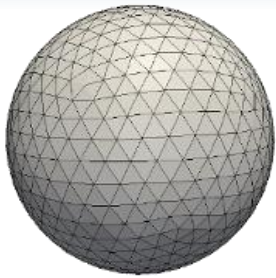

Fluid dynamics

$$\rho \frac{\partial \mathbf{u}}{\partial t} = \mathcal{L}\mathbf{u} + \Lambda[\Upsilon(\mathbf{v} - \Gamma\mathbf{u})] + \lambda + \mathbf{f}_{\text{thm}}$$
$$\nabla \cdot \mathbf{u} = 0$$

Structure dynamics

$$\frac{d\mathbf{X}}{dt} = \mathbf{v}$$
$$m \frac{d\mathbf{v}}{dt} = -\Upsilon(\mathbf{v} - \Gamma\mathbf{u}) - \nabla_{\mathbf{X}}\Phi[\mathbf{X}] + \zeta + \mathbf{F}_{\text{thm}}$$

- Thermal fluctuation propagation **pose challenges** for **non-uniform discretizations**.
- Dissipative numerical operators **need to be compatible** stochastic driving fields.
- Additional time-scales arise from the microstructure – fluid momentum coupling.
- We developed **Finite Element Methods + Stochastic Iterative Methods** for SELM.

Implicit-Solvent Coarse-Grained Models
Lipid Bilayer Membranes

Coarse-Grained Lipid Model

Lipid Interactions

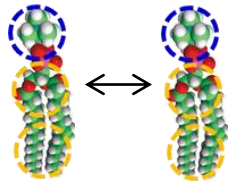

Coarse-Grained Model

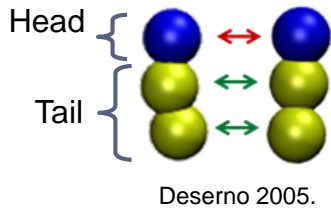

Interaction Potentials

Steric Repulsion: Weeks-Chandler Anderson

$$V_{\text{steric}}(r) = \begin{cases} 4\epsilon [(b/r)^{12} - (b/r)^6 + 1/4], & r \leq r_c, \\ 0, & r > r_c. \end{cases}$$

$r_c = 2^{1/6}b$

Bonds: FENE

$$V_{\text{bond}}(r) = -\frac{1}{2}k_{\text{bond}}r_{\infty}^2 \ln(1 - (r/r_{\infty})^2)$$

Bending

$$V_{\text{bend}}(r) = \frac{1}{2}k_{\text{bend}}(r - 4\sigma)^2$$

Tail-Tail Attraction: Hydrophobic-Hydrophilic Effect

$$V_{\text{tail-tail}}(r) = \begin{cases} -\epsilon, & r < r_c, \\ -\epsilon \cos^2(\pi(r - r_c)/2w_c), & r_c \leq r \leq r_c + w_c, \\ 0, & r > r_c. \end{cases}$$

Deserno 2005.

Lipid Bilayer Membranes

Self-Assembled Bilayers

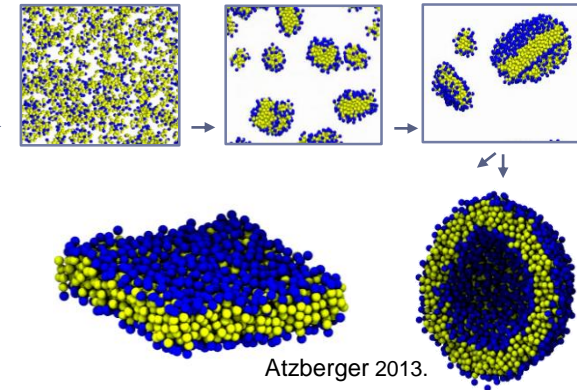

Key Features

- Atomic details coarse-grained to obtain simplified model.
- Lipids represented by a few “beads.”
- Hydrophobic-hydrophilic effect drives bilayer formation.
- Solvent treated implicitly through free energy of interactions.
- Long-range tail-tail interaction drives self-assembly (important to obtain fluid phase).
- IS-CG models widely used for equilibrium. **What about kinetics?**

Phases

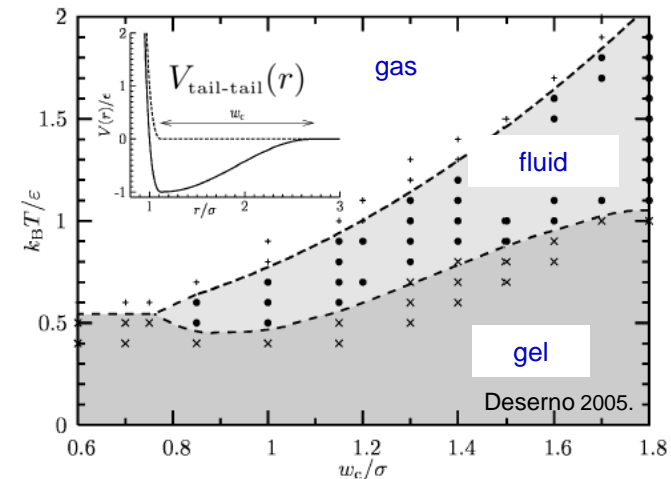

Extending IS-CG Models with Fluctuating Hydrodynamics

Lipid Interactions

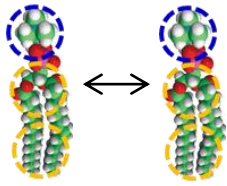

Coarse-Grained Model

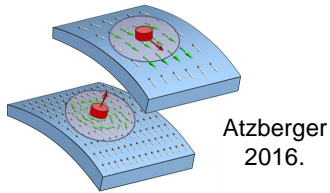
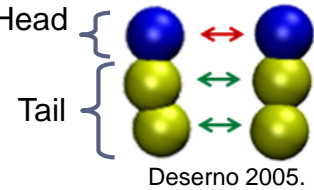

Fluctuating Hydrodynamics

Particle Dynamics:

$$\frac{d\mathbf{X}}{dt} = \mathbf{v}$$

$$m \frac{d\mathbf{v}}{dt} = -\Upsilon(\mathbf{v} - \Gamma\mathbf{u}) - \nabla_X \Phi[X] + \mathbf{F}_{thm}$$

Fluctuating Hydrodynamics (SELM):

$$\rho \frac{\partial \mathbf{u}}{\partial t} = \mu \Delta \mathbf{u} - \nabla p + \Lambda [\Upsilon(\mathbf{v} - \Gamma\mathbf{u})] + \mathbf{f}_{thm}$$

$$\nabla \cdot \mathbf{u} = 0.$$

Thermal Fluctuations

$$\langle \mathbf{f}_{thm}(s) \mathbf{f}_{thm}(t)^T \rangle = -2k_B T (\mu \Delta - \Lambda \Upsilon \Gamma) \delta(t - s)$$

$$\langle \mathbf{F}_{thm}(s) \mathbf{F}_{thm}(t)^T \rangle = 2k_B T \Upsilon \delta(t - s)$$

$$\langle \mathbf{f}_{thm}(s) \mathbf{F}_{thm}(t)^T \rangle = -2k_B T \Lambda \Upsilon \delta(t - s).$$

Coupling by Immersed Boundary Method

$$\Gamma \mathbf{u} = \int_{\Omega} \eta(\mathbf{y} - \mathbf{X}(t)) \mathbf{u}(\mathbf{y}, t) d\mathbf{y}$$

$$\Lambda \mathbf{F} = \eta(\mathbf{x} - \mathbf{X}(t)) \mathbf{F}.$$

Atzberger 2007

Stochastic Eulerian-Lagrangian Method

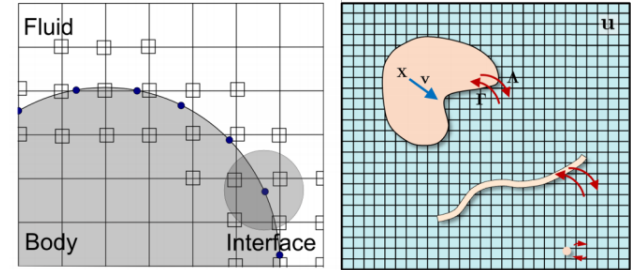

SELM-CG Bilayer Model

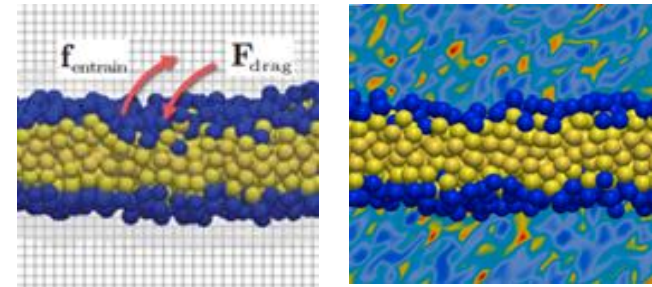

Hydrodynamic Coupling

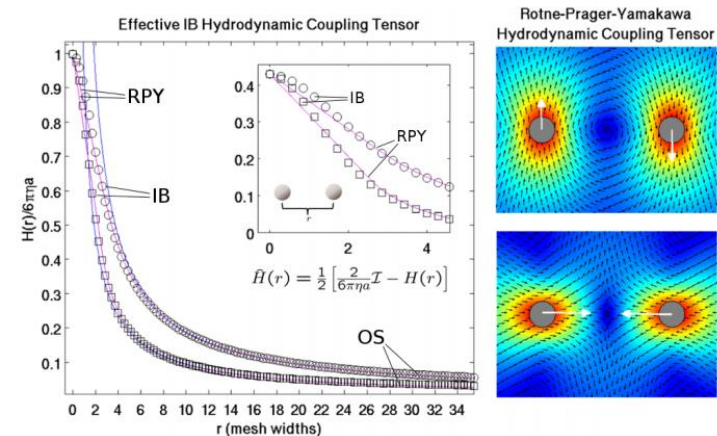

Extending Implicit Solvent Models for Kinetics

- Solvent treated implicitly (free energy contributions).
- Missing momentum transport through solvent.
- Saffman-Delbruck diffusion shows solvent important!
- We introduce fluctuating hydrodynamics to thermostat system.
- Extends IS-CG models for kinetic studies (SELM-CG).

SELM-CG Bilayer Model

SELM-CG Bilayer Model

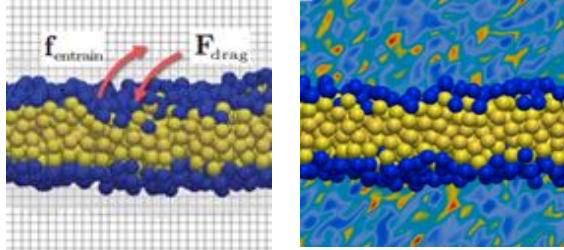

Lipid Vesicles

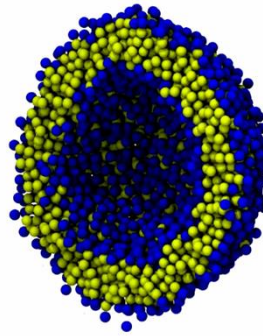

Correlation Analysis

Lipid Vesicle

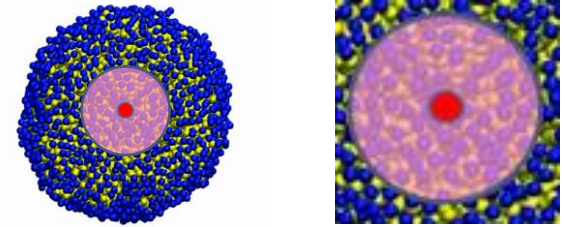

Cluster

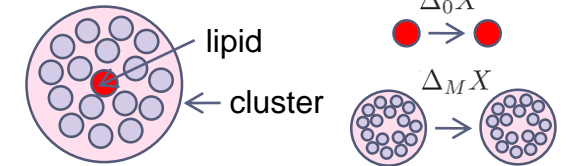

displacement Δt

$\Delta_0 X$

● → ●

$\Delta_M X$

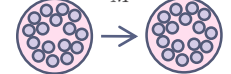

Cluster Correlation: Dynamics

$$c_M = \langle \Delta_0 X \Delta_M X \rangle / \langle \Delta_0 X^2 \rangle$$

Results: SELM vs Langevin Stokes

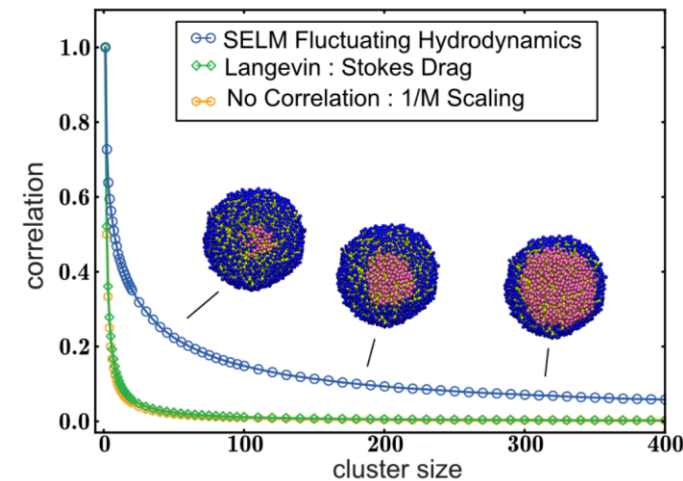

Lipid Dynamics within Vesicle Bilayers

- Saffman-Delbruck diffusion shows solvent is important!
- Lipid motions correlated through direct contacts and solvent flow.
- Langevin dynamics models momentum transfer as local.
- Lipid dynamics: consider correlations within a cluster.
- SELM-CG vs Langevin dynamics (Stokes drag).
- Langevin drag suppresses lateral correlations.
- SELM exhibits long-range correlations.

SELM-CG Bilayer Model

SELM-CG Bilayer Model

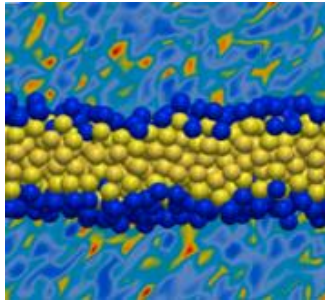
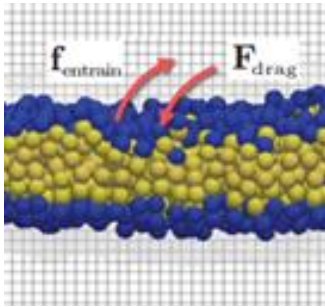

Lipid Vesicles

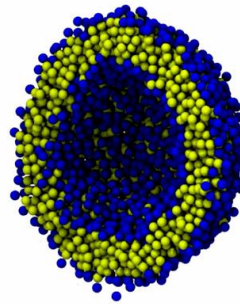

Results

Langevin: Stokes Drag

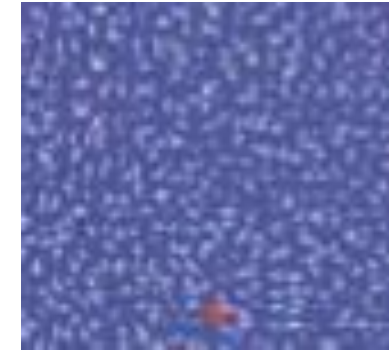

Correlation Analysis

Two-point correlation

Displacement Δt

Spatial Correlation

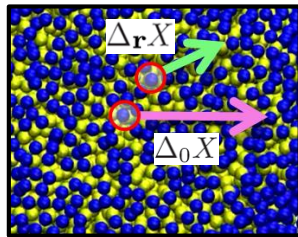
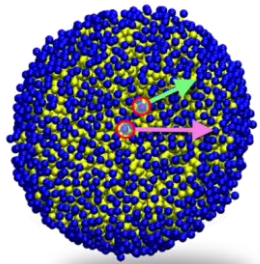

$$\Psi(\mathbf{r}) = \langle \Delta_{\mathbf{r}} X \Delta_0 X^T \rangle$$

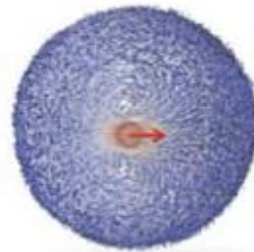

SELM: Fluctuating Hydrodynamics

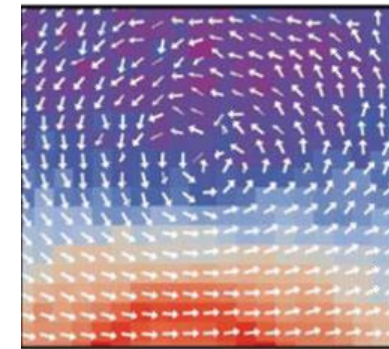

Langevin: Small Drag

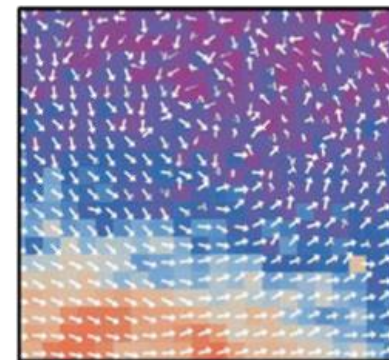

Lipid Dynamics within Vesicle Bilayers

- Spatial analysis of lipid motions (passive fluctuations).
- Two point correlations (linear response to point force).
- SELM vs Langevin Dynamics.

Hydrodynamics of Spherical Vesicles

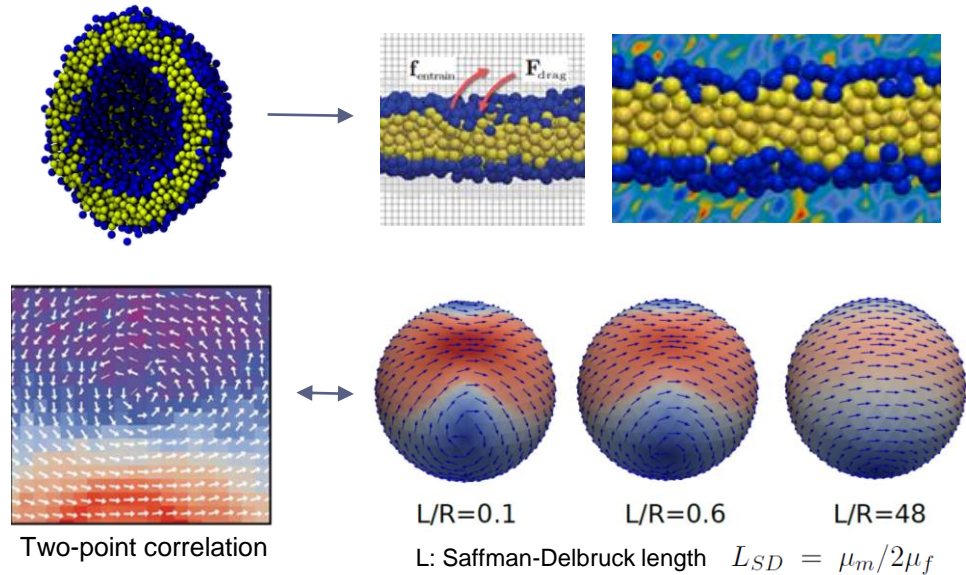
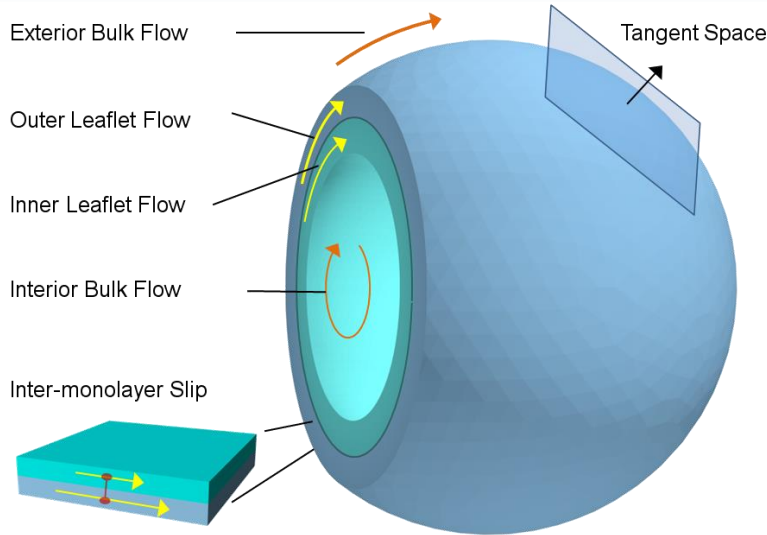

Hydrodynamics Covariant Formulation

Fluid Equations (Stokes Flow)

$$\begin{cases} \mu_m (-\delta \mathbf{d}\mathbf{v}^b + 2K\mathbf{v}^b) - \mathbf{d}p + \mathbf{b}^b = 0 \\ -\delta \mathbf{v}^b = 0. \end{cases}$$

Lipid Bilayer Membrane Hydrodynamics

$$\begin{cases} \mu_m [-\delta \mathbf{d}\mathbf{v}_+^b + 2K_+ \mathbf{v}_+^b] + \mathbf{t}_+^b - \gamma (\mathbf{v}_+^b - \mathbf{v}_-^b) \\ = \mathbf{d}p_+ - \mathbf{b}_+^b = -\mathbf{c}_+^b, & \mathbf{x} \in \Gamma_+ \\ \delta \mathbf{v}_+^b = 0, & \mathbf{x} \in \Gamma_+, \\ \mu_m [-\delta \mathbf{d}\mathbf{v}_-^b + 2K_- \mathbf{v}_-^b] + \mathbf{t}_-^b - \gamma (\mathbf{v}_-^b - \mathbf{v}_+^b) \\ = \mathbf{d}p_- - \mathbf{b}_-^b = -\mathbf{c}_-^b, & \mathbf{x} \in \Gamma_- \\ \delta \mathbf{v}_-^b = 0, & \mathbf{x} \in \Gamma_-. \end{cases}$$

Responses (spherical harmonics)

$$\mathbf{v}_\pm^b = -\star \mathbf{d} \sum_s a_s^\pm \Phi_s$$

$$\begin{bmatrix} a_s^+ \\ a_s^- \end{bmatrix} = \mathcal{A}_s^{-1} \begin{bmatrix} -c_s^+ \\ -c_s^- \end{bmatrix}$$

$$\mathcal{A}_s = \begin{bmatrix} A_1^\ell - \gamma & \gamma \\ \gamma & A_2^\ell - \gamma \end{bmatrix}$$

$$A_1^\ell = \frac{\mu_m}{R_+^2} \left(2 - \ell(\ell+1) - \frac{R_+}{L^+}(\ell+1) \right)$$

$$A_2^\ell = \frac{\mu_m}{R_-^2} \left(2 - \ell(\ell+1) - \frac{R_-}{L^-}(\ell-1) \right)$$

Exterior Calculus

$$g^{ac} g^{bd} v_{c|d|b} = (\Delta^R \mathbf{v})^a + K v^a$$

$$g^{ac} g^{bd} v_{d|c|b} = \text{grad}(\text{div}(\mathbf{v})) + K v^a = K v^a.$$

$$\text{grad}(f) = [\mathbf{d}f]^\sharp$$

$$\text{div}(\mathbf{F}) = -(\star \mathbf{d} \star \mathbf{F}^b) = -\delta \mathbf{F}^b$$

$$\text{curl}(\mathbf{F}) = [\star(\mathbf{d}\mathbf{F}^b)]^\sharp.$$

$$\Delta^R f = -(\star \mathbf{d} \star) \mathbf{d}f = -\delta \mathbf{d}f.$$

$$\text{div}(\mathbf{D}) = -\delta \mathbf{d}\mathbf{v}^b + 2K\mathbf{v}^b.$$

Hydrodynamics of Spherical Vesicles

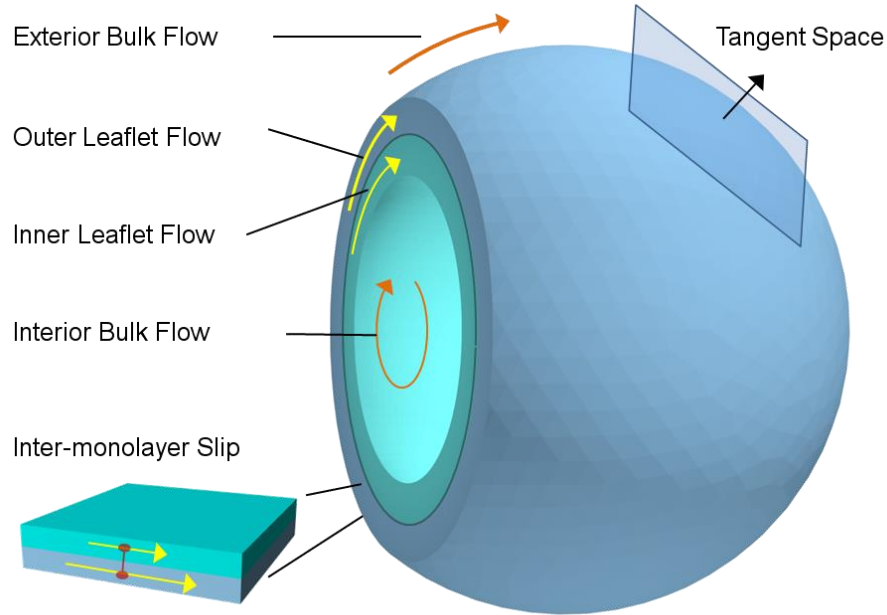

Flow on Sphere and Pseudosphere

Tangent Constant
(flow transport)

Cotangent Constant
(flow transport)

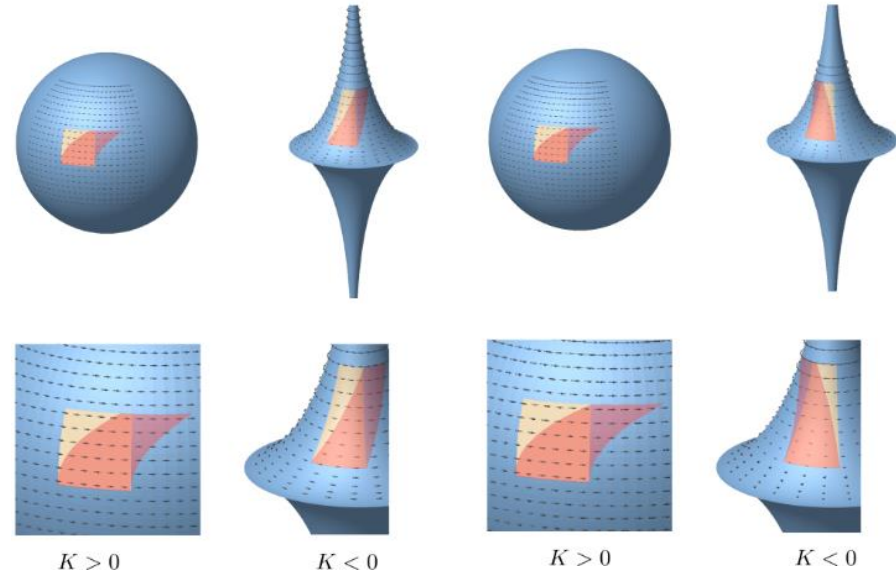

Hydrodynamics on Surfaces : Curvature Induced Shear

- Curvature plays role in Newtonian stresses on surface.
- Intrinsic curvature \rightarrow Gaussian curvature appears.
- Shear induced even by “constant” velocity fields!
- Two types of “constant” fields of interest on surface
 - tangent vector is constant (covariant deriv. zero).
 - co-tangent vector is constant (exterior deriv. zero).

Stokes Flow

$$\begin{cases} \mu_m (-\delta \mathbf{d}\mathbf{v}^b + 2K\mathbf{v}^b) - \mathbf{d}p + \mathbf{b}^b & = 0 \\ -\delta \mathbf{v}^b & = 0. \end{cases}$$

Lipid Bilayer Membrane Hydrodynamics

$$\begin{cases} \mu_m [-\delta \mathbf{d}\mathbf{v}_+^b + 2K_+ \mathbf{v}_+^b] + \mathbf{t}_+^b - \gamma (\mathbf{v}_+^b - \mathbf{v}_-^b) \\ \quad = \mathbf{d}p_+ - \mathbf{b}_+^b = -\mathbf{c}_+^b, & \mathbf{x} \in \Gamma_+ \\ \delta \mathbf{v}_+^b = 0, & \mathbf{x} \in \Gamma_+, \\ \mu_m [-\delta \mathbf{d}\mathbf{v}_-^b + 2K_- \mathbf{v}_-^b] + \mathbf{t}_-^b - \gamma (\mathbf{v}_-^b - \mathbf{v}_+^b) \\ \quad = \mathbf{d}p_- - \mathbf{b}_-^b = -\mathbf{c}_-^b, & \mathbf{x} \in \Gamma_- \\ \delta \mathbf{v}_-^b = 0, & \mathbf{x} \in \Gamma_-. \end{cases}$$

Hydrodynamics of Spherical Vesicles

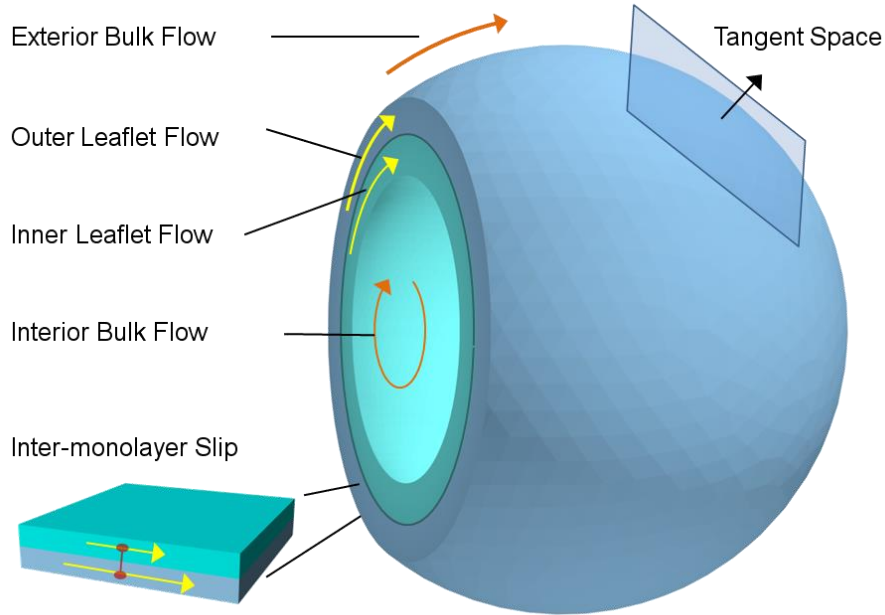

Viscosity and Vortex Position

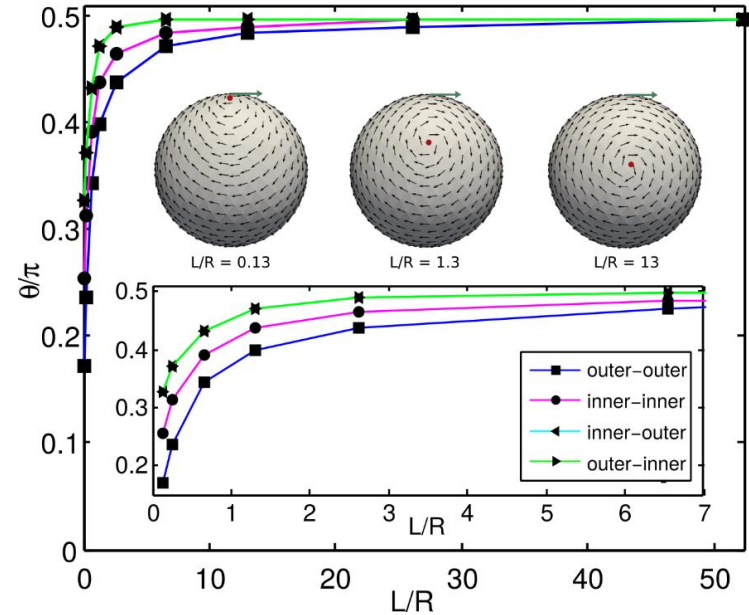

Hydrodynamics on Surfaces : Viscosity and Vortices

- Spherical topology requires in-plane flow to have vortex.
- Consider flow induced by point force at north-pole.
- Membrane viscosity closely related to the steady-state vortex location.
- Inner and outer vortex locations are offset when there is inter-monolayer slip.

Stokes Flow

$$\begin{cases} \mu_m (-\delta \mathbf{d}\mathbf{v}^b + 2K\mathbf{v}^b) - \mathbf{d}p + \mathbf{b}^b = 0 \\ -\delta \mathbf{v}^b = 0 \end{cases}$$

Lipid Bilayer Membrane Hydrodynamics

$$\begin{cases} \mu_m [-\delta \mathbf{d}\mathbf{v}_+^b + 2K_+ \mathbf{v}_+^b] + \mathbf{t}_+^b - \gamma (\mathbf{v}_+^b - \mathbf{v}_-^b) \\ = \mathbf{d}p_+ - \mathbf{b}_+^b = -\mathbf{c}_+^b, & \mathbf{x} \in \Gamma_+ \\ \delta \mathbf{v}_+^b = 0, & \mathbf{x} \in \Gamma_+, \\ \mu_m [-\delta \mathbf{d}\mathbf{v}_-^b + 2K_- \mathbf{v}_-^b] + \mathbf{t}_-^b - \gamma (\mathbf{v}_-^b - \mathbf{v}_+^b) \\ = \mathbf{d}p_- - \mathbf{b}_-^b = -\mathbf{c}_-^b, & \mathbf{x} \in \Gamma_- \\ \delta \mathbf{v}_-^b = 0, & \mathbf{x} \in \Gamma_- \end{cases}$$

Mobility of Protein Inclusions within Surface

Protein Inclusion in Leaflet

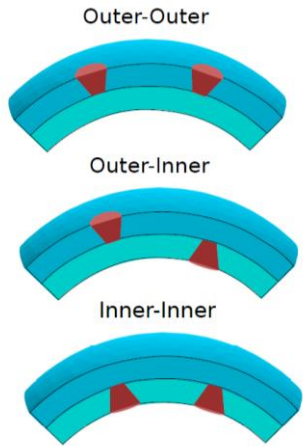

Immersed Boundary Coupling

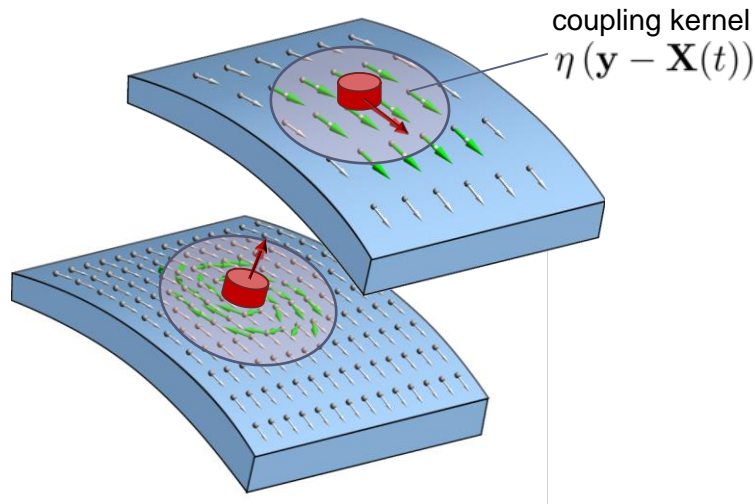

Mobility Response (Force / Torque)

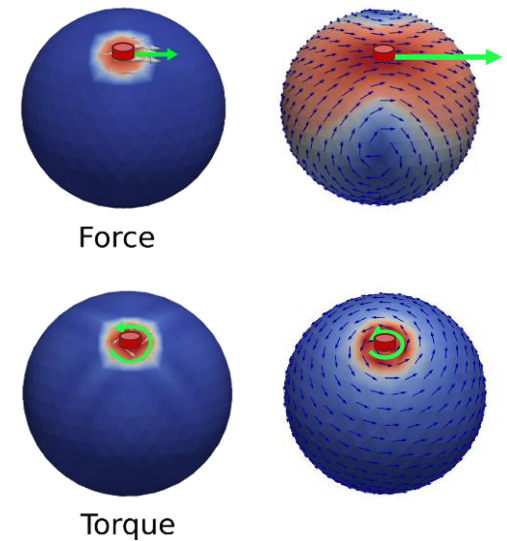

Mobility of Inclusions

- Protein-Lipid Coupling \rightarrow Immersed Boundary Coupling (manifold operators)
- Proteins embedded within inner or outer leaflet of bilayer.

- Mobility tensor between particle i and particle j

$$M_{ij} = \Gamma_i \mathcal{S} \Lambda_j$$

$$\Gamma \mathbf{u} = \int_{\Omega} \eta(\mathbf{y} - \mathbf{X}(t)) \mathbf{u}(\mathbf{y}, t) d\mathbf{y}$$

$$\Lambda \mathbf{F} = \eta(\mathbf{x} - \mathbf{X}(t)) \mathbf{F}.$$

solution flow \mathcal{S} .

- Adjoint condition $\Gamma^T = \Lambda$

- Translational and rotational mobilities.

Lipid Bilayer Hydrodynamics

$$\left\{ \begin{array}{l} \mu_m [-\delta d\mathbf{v}_+^b + 2K_+ \mathbf{v}_+^b] + \mathbf{t}_+^b - \gamma (\mathbf{v}_+^b - \mathbf{v}_-^b) \\ = d\mathbf{p}_+ - \mathbf{b}_+^b = -\mathbf{c}_+^b, \quad \mathbf{x} \in \Gamma_+ \\ \delta \mathbf{v}_+^b = 0, \quad \mathbf{x} \in \Gamma_+, \\ \mu_m [-\delta d\mathbf{v}_-^b + 2K_- \mathbf{v}_-^b] + \mathbf{t}_-^b - \gamma (\mathbf{v}_-^b - \mathbf{v}_+^b) \\ = d\mathbf{p}_- - \mathbf{b}_-^b = -\mathbf{c}_-^b, \quad \mathbf{x} \in \Gamma_- \\ \delta \mathbf{v}_-^b = 0, \quad \mathbf{x} \in \Gamma_-. \end{array} \right.$$

Hydrodynamic Flow within Bilayer

Mobility vs Position : (viscosity or slip varied)

Leaflet Cases (Inner/Outer)

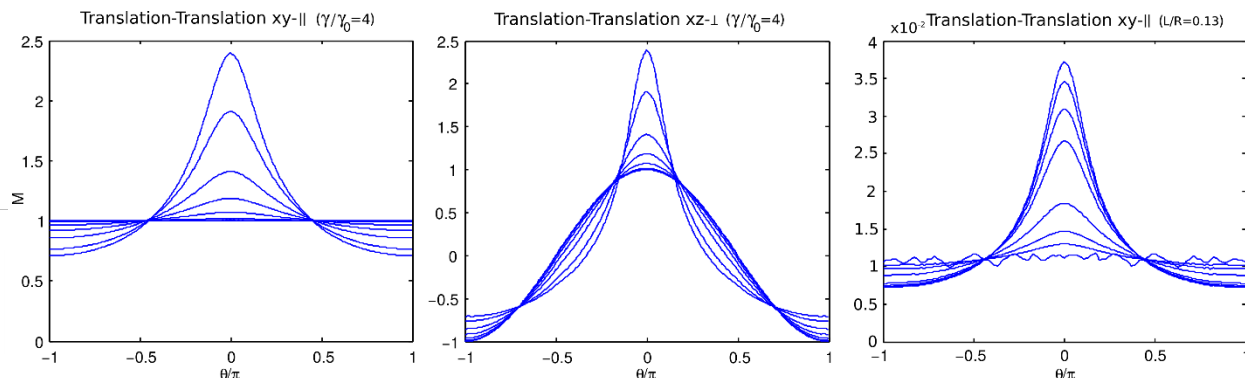
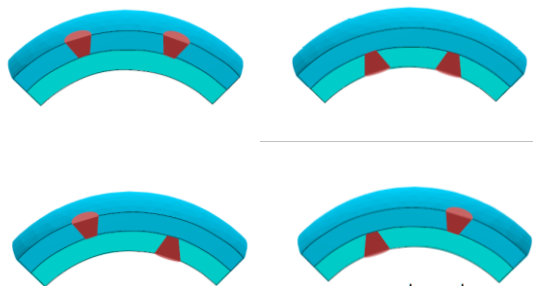

Translation and Rotation Cases

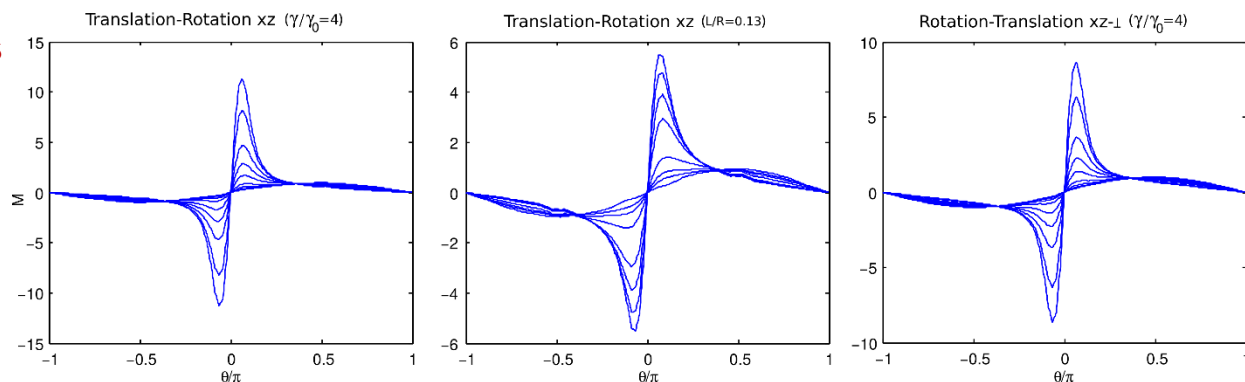
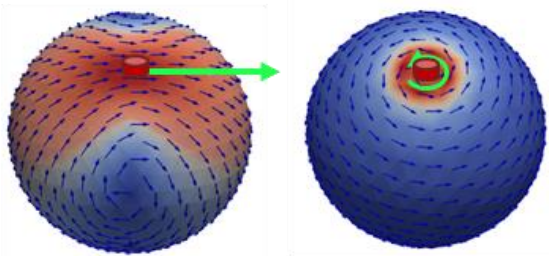

Mobility Cross-Sections

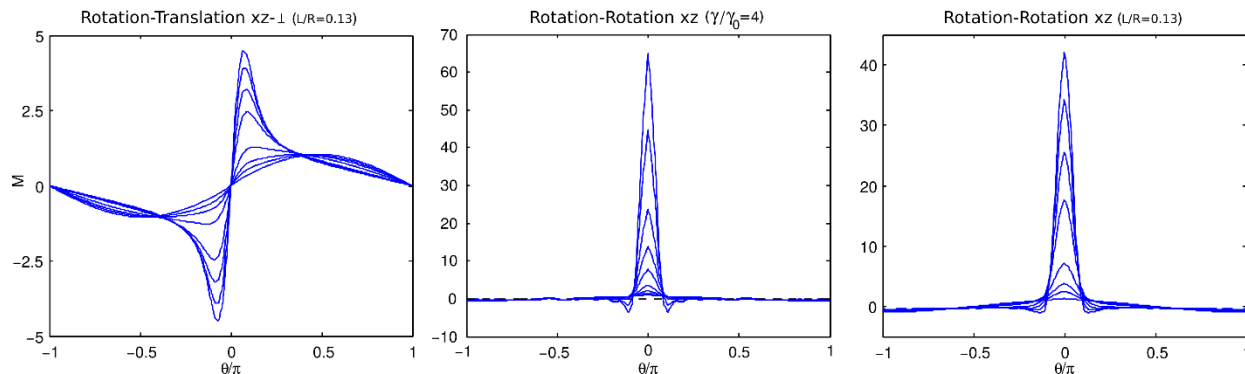
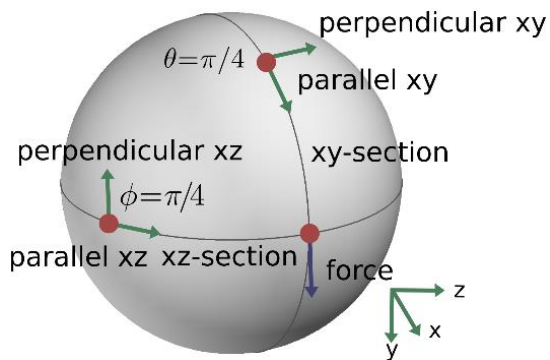

Mobility vs Membrane Viscosity

Mobility Cross-Sections

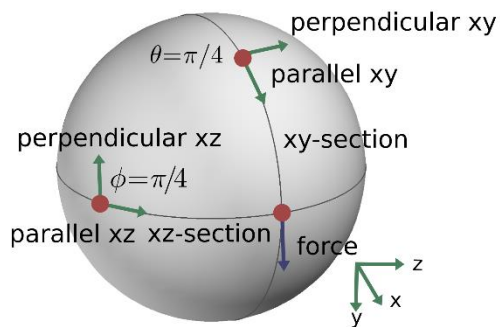

IB-Coupling

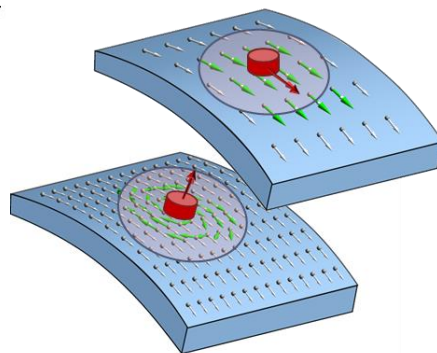

Leaflet Cases

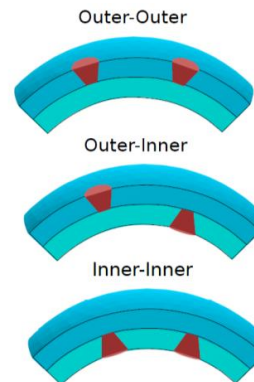

Response to Force/Torque

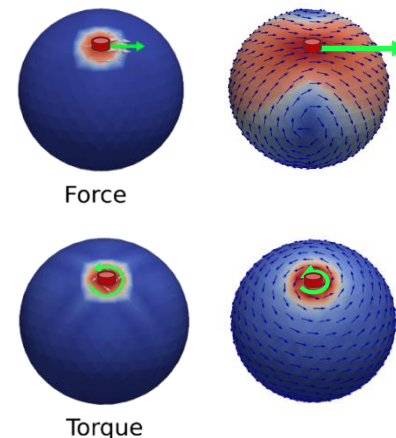

Mobility : (viscosity varied)

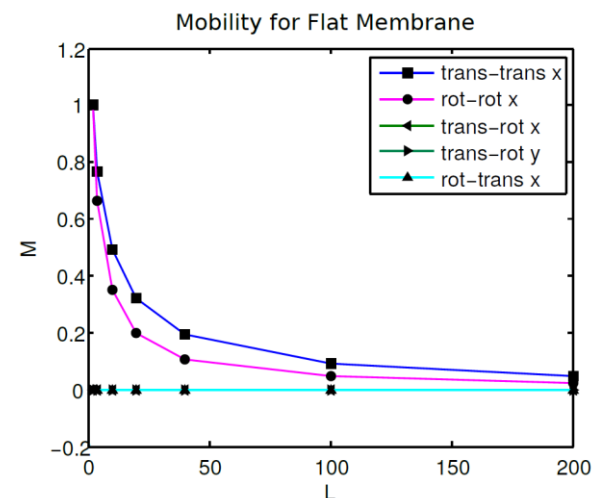
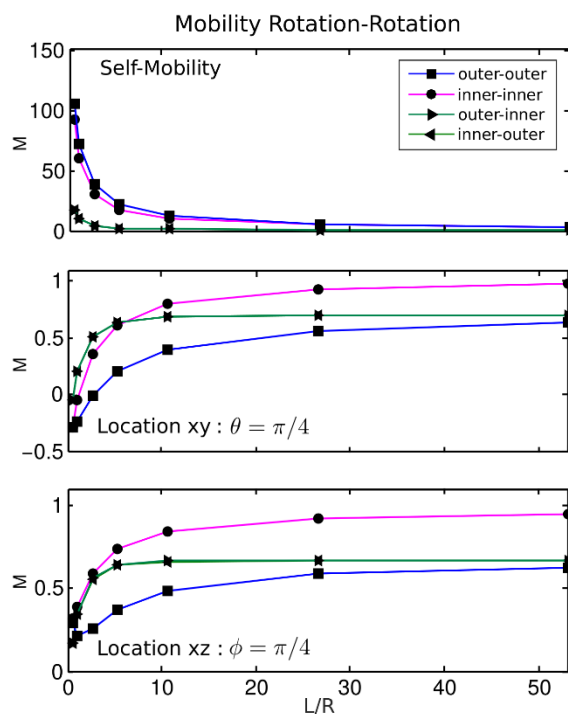
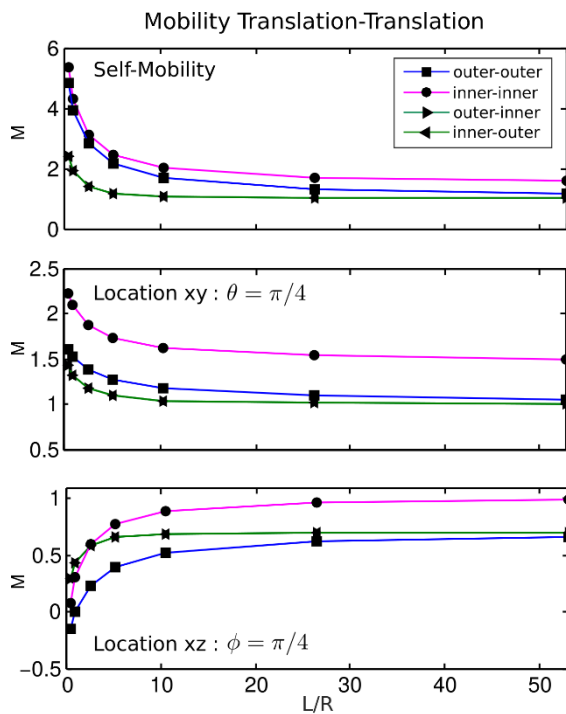

Mobility vs Intermolecular Slip

Mobility Cross-Sections

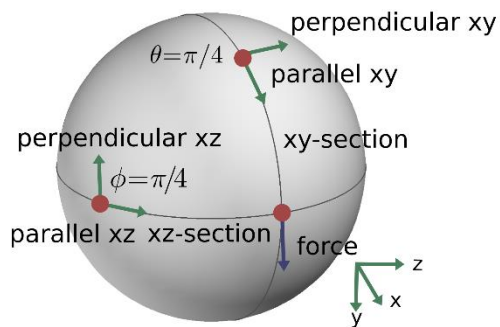

IB-Coupling

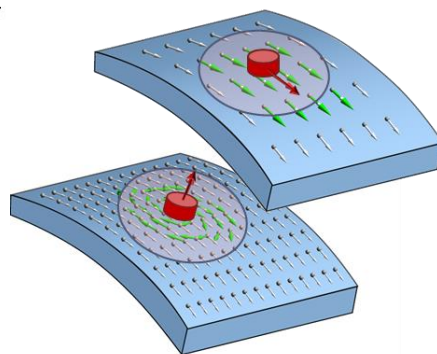

Leaflet Cases

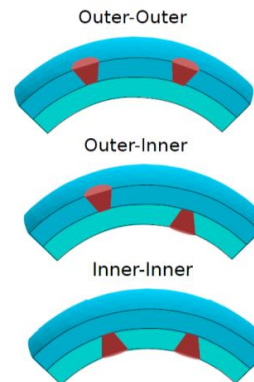

Response to Force/Torque

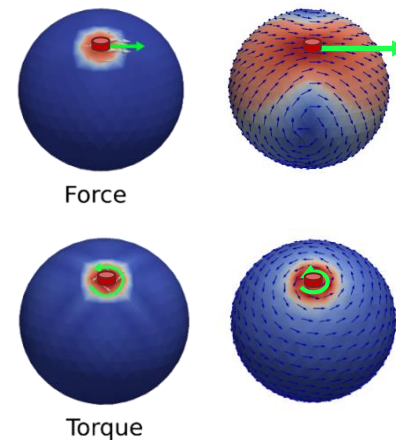

Mobility : (intermonolayer slip varied)

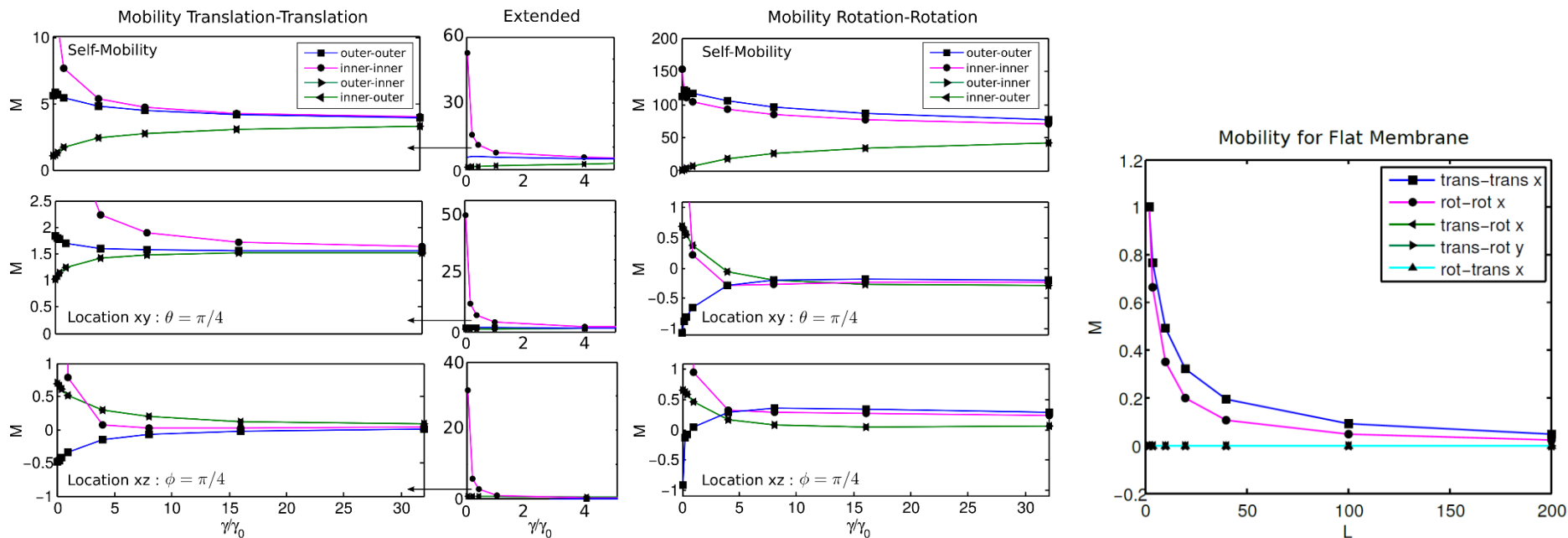

Many Particle Interactions

Many Particle Systems

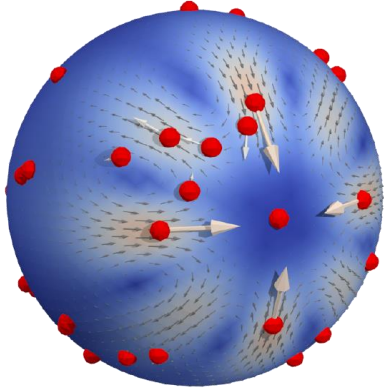

Mobility Cross-Section

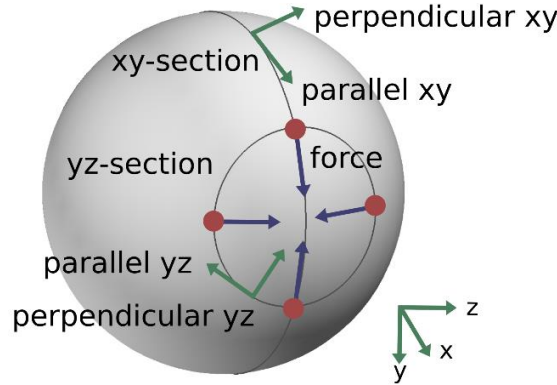

Mobility vs Position

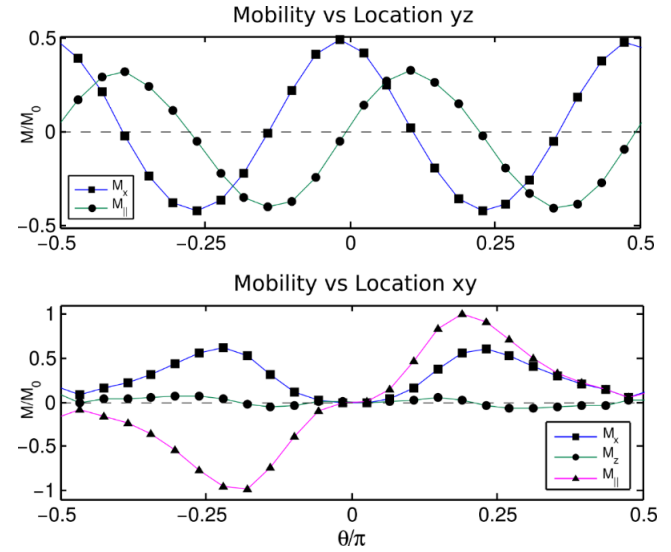

Multiple-particle Dynamics within Vesicles

$$\frac{d\mathbf{X}}{dt} = \mathbf{M}\mathbf{F} + k_B T \nabla \cdot \mathbf{M} + \mathbf{F}_{thm}$$

$$\langle \mathbf{F}_{thm}(s) \mathbf{F}_{thm}(t)^T \rangle = 2k_B T \mathbf{M} \delta(t - s).$$

\mathbf{M}
solution flow

- Mobility obtained from solving bilayer hydrodynamic equations.
- Illustration : attracting cluster of particles on spherical surface.
- Finite domain size + incompressibility requires re-circulation of fluid.
- Rich dynamics on spherical surface from finite domain size + topology (vortex for any tangential flow, packing restrictions).
- Protein assembly, collective kinetics, etc...

Lipid Bilayer Hydrodynamics

$$\left\{ \begin{array}{l} \mu_m [-\delta \mathbf{d}\mathbf{v}_+^b + 2K_+ \mathbf{v}_+^b] + \mathbf{t}_+^b - \gamma (\mathbf{v}_+^b - \mathbf{v}_-^b) \\ = \mathbf{d}p_+ - \mathbf{b}_+^b = -\mathbf{c}_+^b, \quad \mathbf{x} \in \Gamma_+ \\ \delta \mathbf{v}_+^b = 0, \quad \mathbf{x} \in \Gamma_+, \\ \\ \mu_m [-\delta \mathbf{d}\mathbf{v}_-^b + 2K_- \mathbf{v}_-^b] + \mathbf{t}_-^b - \gamma (\mathbf{v}_-^b - \mathbf{v}_+^b) \\ = \mathbf{d}p_- - \mathbf{b}_-^b = -\mathbf{c}_-^b, \quad \mathbf{x} \in \Gamma_- \\ \delta \mathbf{v}_-^b = 0, \quad \mathbf{x} \in \Gamma_- \end{array} \right.$$

Conclusions

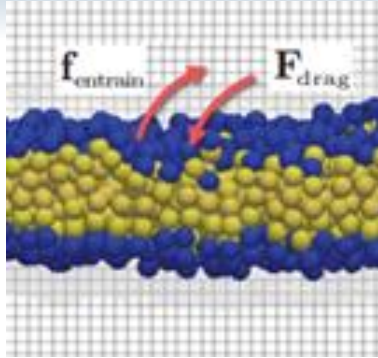

Coarse-Grained Lipid Models
Fluctuating Hydrodynamics Approaches

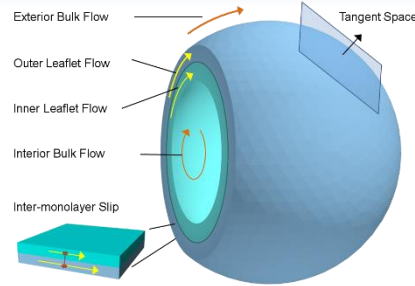

Continuum Mechanics of Bilayer Membranes
Fluctuating Hydrodynamics Approaches

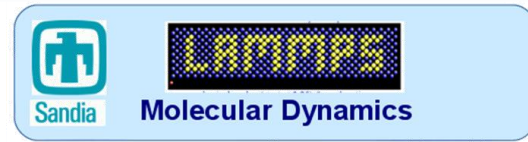

<http://mango-selm.org/>

Summary

- Stochastic Eulerian Lagrangian Method (SELM) for fluctuating hydrodynamic descriptions of mesoscale systems.
- SELM incorporates into traditional hydrodynamic and CFD approaches the role of thermal fluctuations.
- Developed both coarse-grained and continuum approaches for lipid bilayer membranes.
- Many other applications: polymeric fluids, colloidal systems, electrokinetics, microfluidics.
- Open source package in LAMMPS MD for SELM simulations: <http://mango-selm.org/>

Recent Students / Post-docs

- J. K. Sigurdsson
- B. Gross
- G. Tabak
- P. Plunkett
- Y. Wang
- K. Sikorski
- Inderbir Sidhu

Funding

- NSF CAREER
- DOE CM4
- Keck Foundation

more information: <http://atzberger.org/>

Publications

Hydrodynamic Coupling of Particle Inclusions Embedded in Curved Lipid Bilayer Membranes, J.K. Sigurdsson and P.J. Atzberger, (submitted), (2016) <http://arxiv.org/abs/1601.06461>

Fluctuating Hydrodynamics Methods for Dynamic Coarse-Grained Implicit-Solvent Simulations in LAMMPS, Y. Wang, J. K. Sigurdsson, and P.J. Atzberger, SIAM J. Sci. Comp. (accepted), (2016).

Systematic Stochastic Reduction of Inertial Fluid-Structure Interactions subject to Thermal Fluctuations, G. Tabak and P.J. Atzberger, SIAM J. Appl. Math., 75(4), 1884–1914, (2015).

Spatially Adaptive Stochastic Methods for Fluid-Structure Interactions Subject to Thermal Fluctuations in Domains with Complex Geometries, P. Plunkett, J. Hu, C. Siefert, P.J. Atzberger, Journal of Computational Physics, Vol. 277, 15 Nov. 2014, pg. 121--137, (2014).

Dynamic Implicit-Solvent Coarse-Grained Models of Lipid Bilayer Membranes : Fluctuating Hydrodynamics Thermostat, Y. Wang, J. K. Sigurdsson, E. Brandt, and P.J. Atzberger, Phys. Rev. E 88, 023301, (2013).

Stochastic Eulerian Lagrangian Methods for Fluid Structure Interactions with Thermal Fluctuations, P.J. Atzberger, J. of Comp. Phys., 230, pp. 2821--2837, (2011).

A Stochastic Immersed Boundary Method for Fluid-Structure Dynamics at Microscopic Length Scales, P.J. Atzberger, P.R. Kramer, and C.S. Peskin, J. Comp. Phys., Vol. 224, Iss. 2, (2007).

