

Free energy sampling for electrochemical systems

Mira Todorova, Anoop Kishore Vatti, Suhyun Yoo
and Jörg Neugebauer



Max-Planck-Institut
für Eisenforschung GmbH

Department of Computational Materials Design
Düsseldorf, Germany

m.todorova@mpie.de

IPAM, 18. 10. 2017

Example: Galvanised steel surface

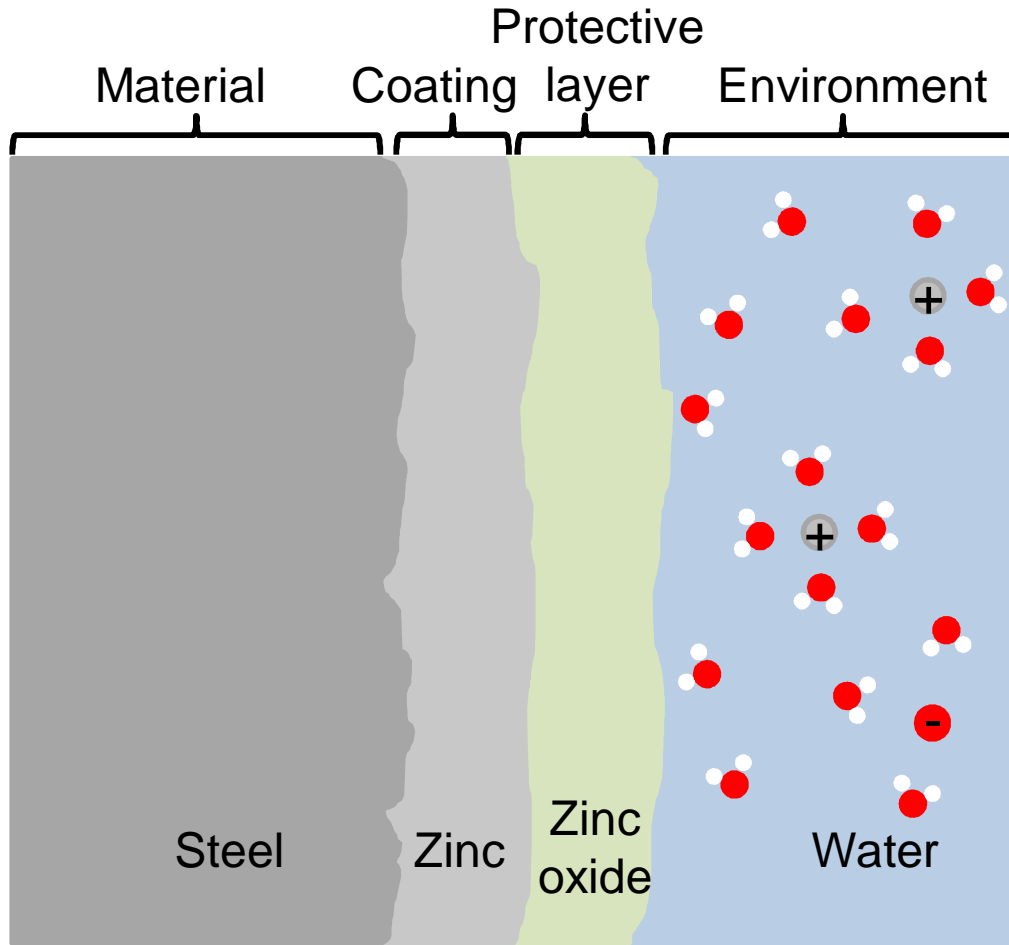

- ∅ Very different materials classes
- ∅ Find a suitable descriptor
- ∅ Translate materials complexity into representative atomistic structures

Approach: Employ chemical potentials



Combine density functional theory with thermodynamic concepts
→ chemical potentials

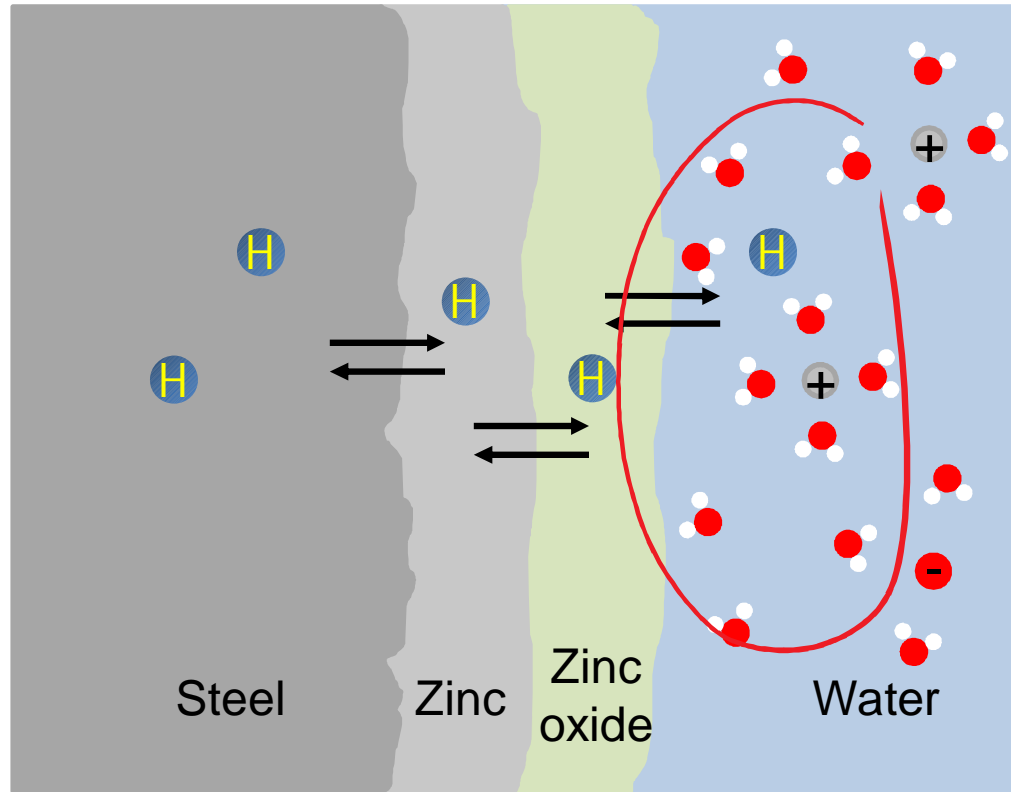

Gibbs free energy

$$\mu_{\alpha} = \frac{\partial G}{\partial n_{\alpha}}$$

Number of atoms
of species a

Chemical potentials allow to compute the relevant structural units separately (divide and conquer)

Solvation via explicit solvent

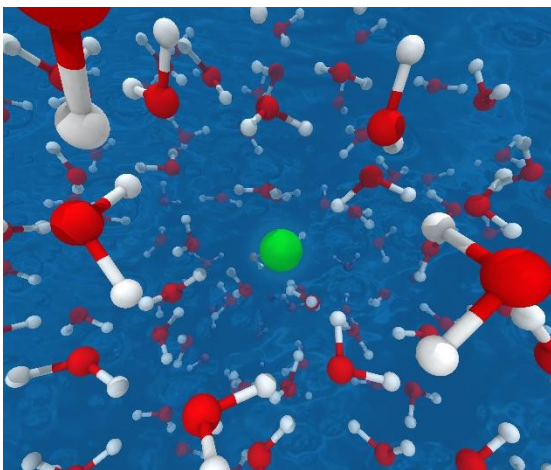

- ∅ Free energies:
 - accessible time scales for MD simulations

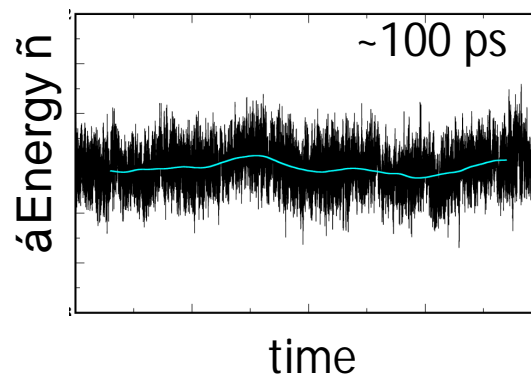

+ flexibility

- ∅ solvation shell and its dynamics
- ∅ different types of bonding and charge
- ∅ electronic structure

- computationally expensive

- ∅ restricted number of atoms (e.g. 32 H₂O)
- ∅ min 10⁴...10⁵ configurations
- ∅ band gap problem (xc-Functional)

Solvation via explicit solvent

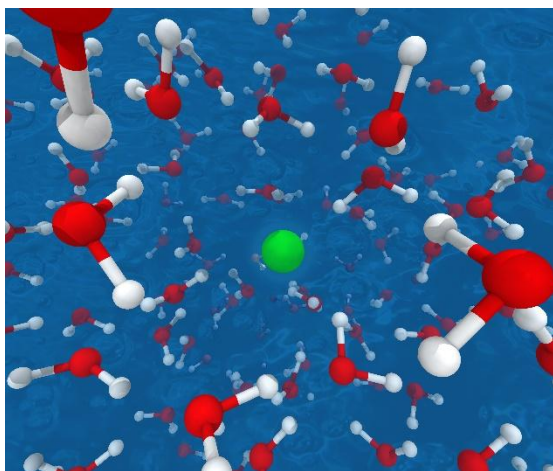

Solvation via implicit solvent

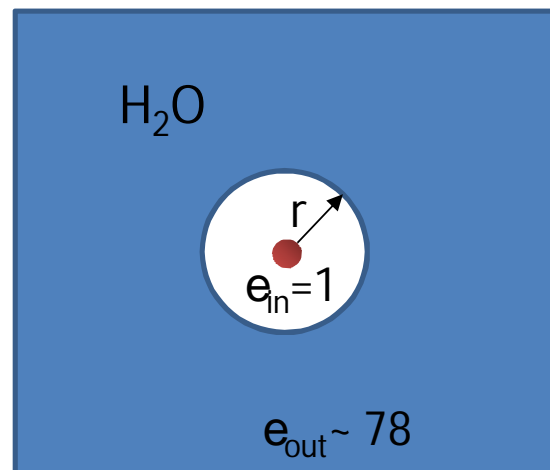

Rough

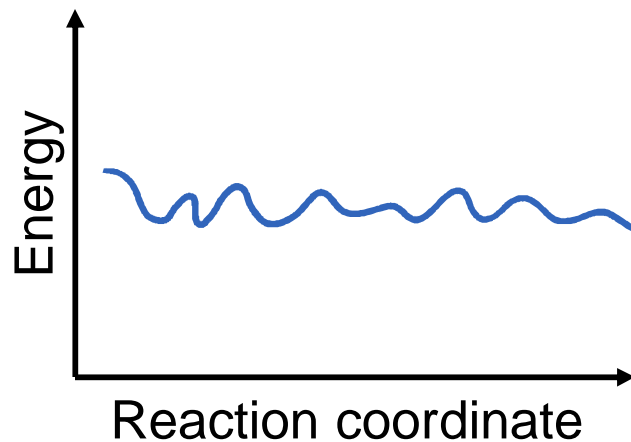

Smooth

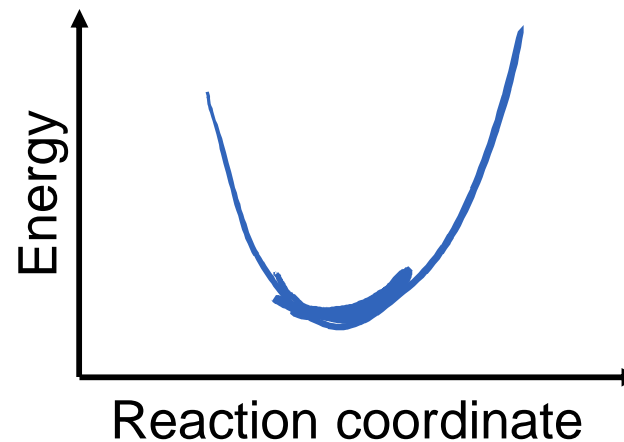

Solvation via explicit solvent

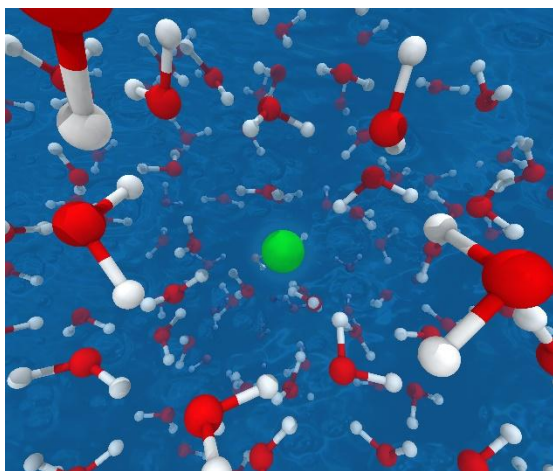

Solvation via implicit solvent

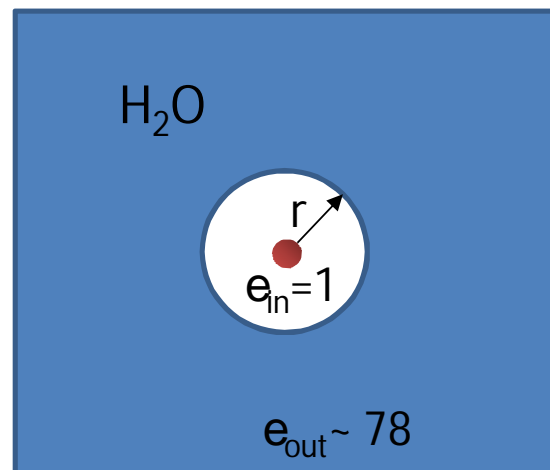

+ flexibility

- ∅ solvation shell and its dynamics
- ∅ different types of bonding and charge
- ∅ electronic structure

- computationally expensive

+ computationally efficient

- cavity (extend and shape)
- bonding
- electronic structure (i.e. distinction between optical and thermodynamic charge transition (redox) levels)

Suhyun Yoo

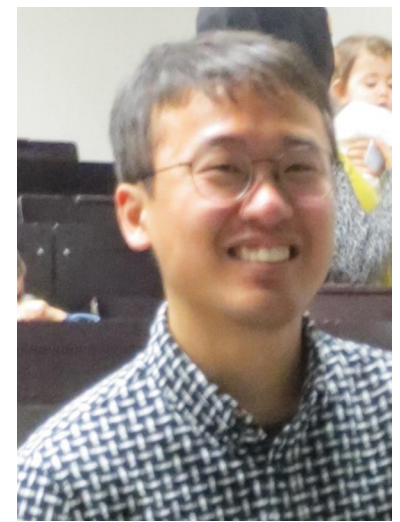

Surface stability in electrochemical environment

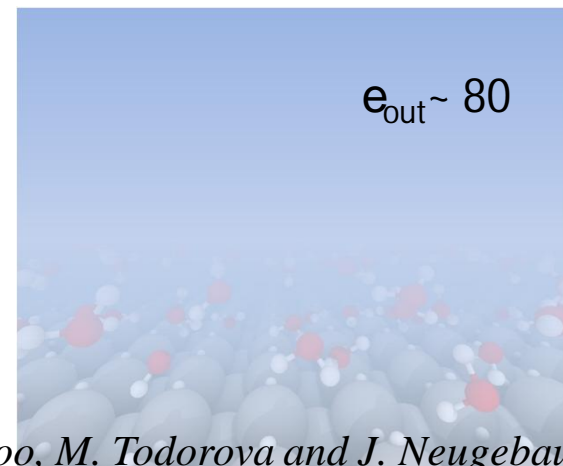
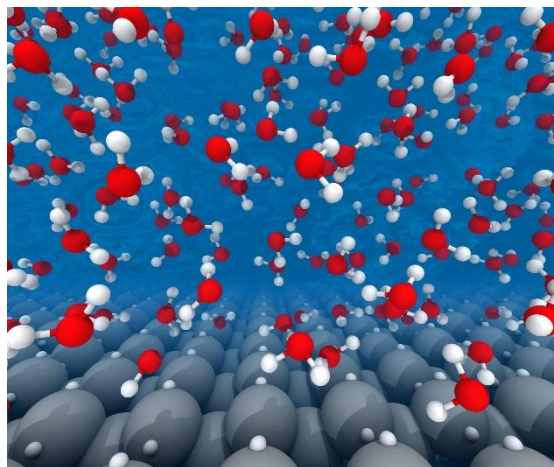

S. Yoo, M. Todorova and J. Neugebauer (submitted)

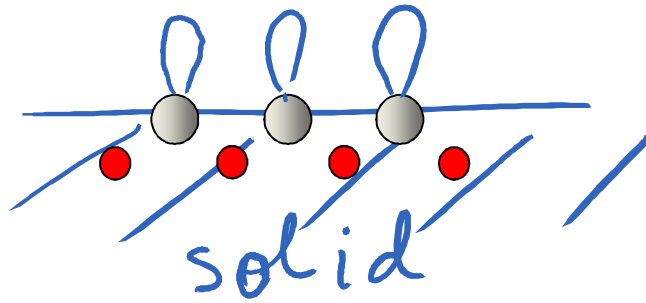

ZnO: some general remarks

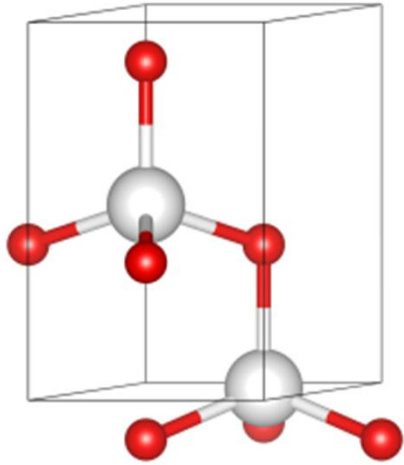

Bulk ZnO
(wurtzite structure)

$1/2 e^-$ per Zn

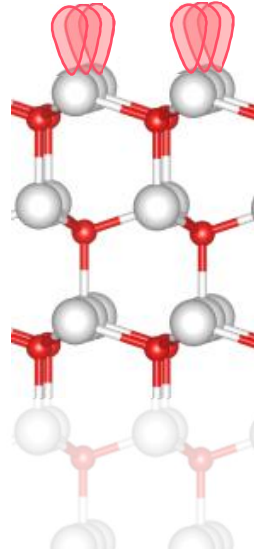

Zn(0001) polar
surfaces

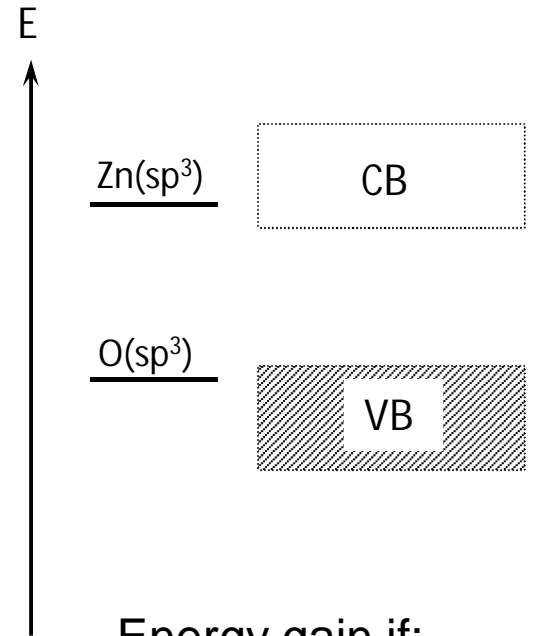

Energy gain if:
 $Zn-sp^3$ is empty
 $O-sp^3$ is filled

► Electron transfer
from Zn to O

- Wide band-gap semiconductor
- Atoms: sp^3 hybridised

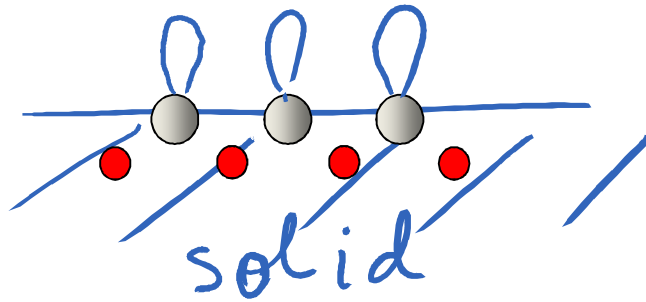

Surface reconstructions (also relevant for 2D materials)

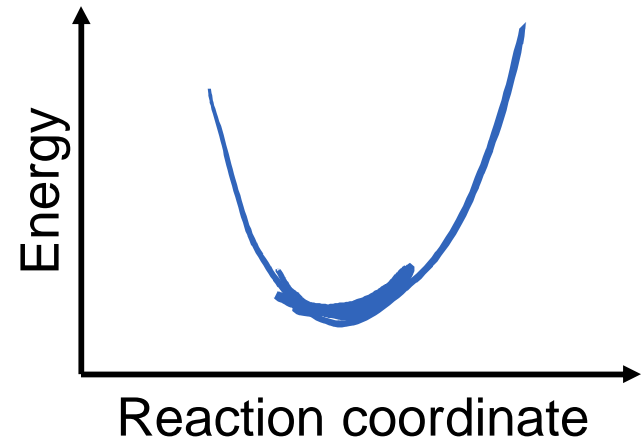
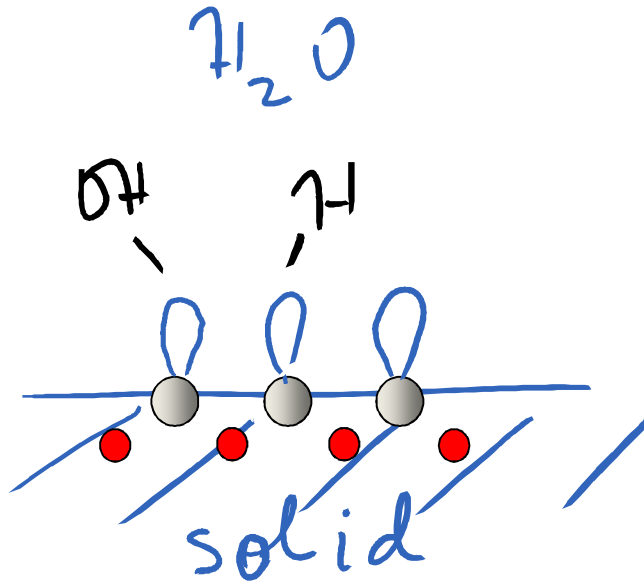

Surface reconstructions (also relevant for 2D materials)

Easy availability of OH and H → surface adsorption

Find for each set of (pH , U) the phase with the lowest Gibbs free energy of formation

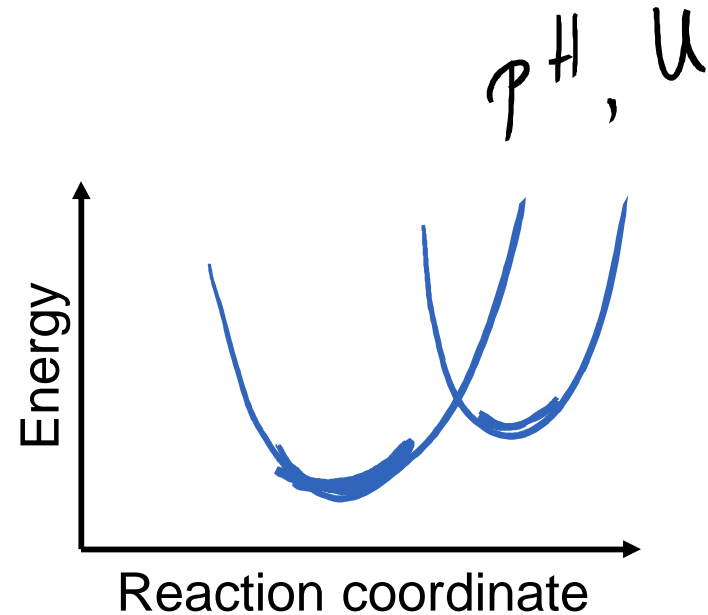
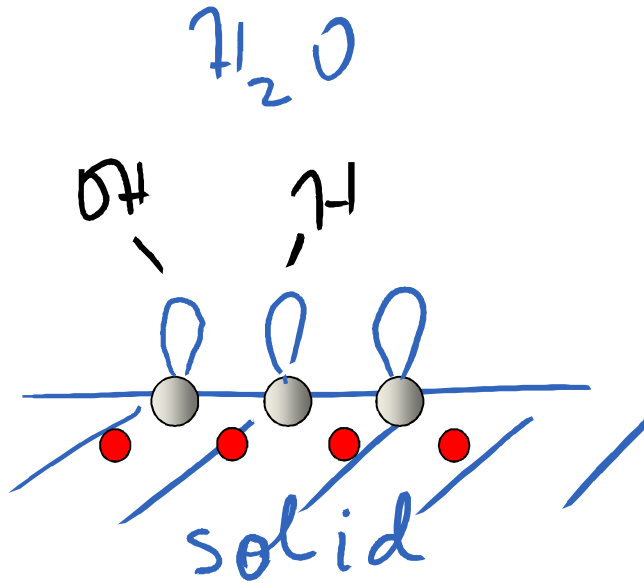

Surface reconstructions (also relevant for 2D materials)

Easy availability of OH and $H \rightarrow$ surface adsorption

Screening capabilities of the solvent

Phase diagrams and chemical potentials



Find for each set of (pH , U) the phase with the lowest Gibbs free energy of formation

Evaluate excess Gibbs free energy: $DG^a \gg E_{\text{tot}}^a - E_{\text{clean}} - \sum_i N_i m_i(pH, U)$

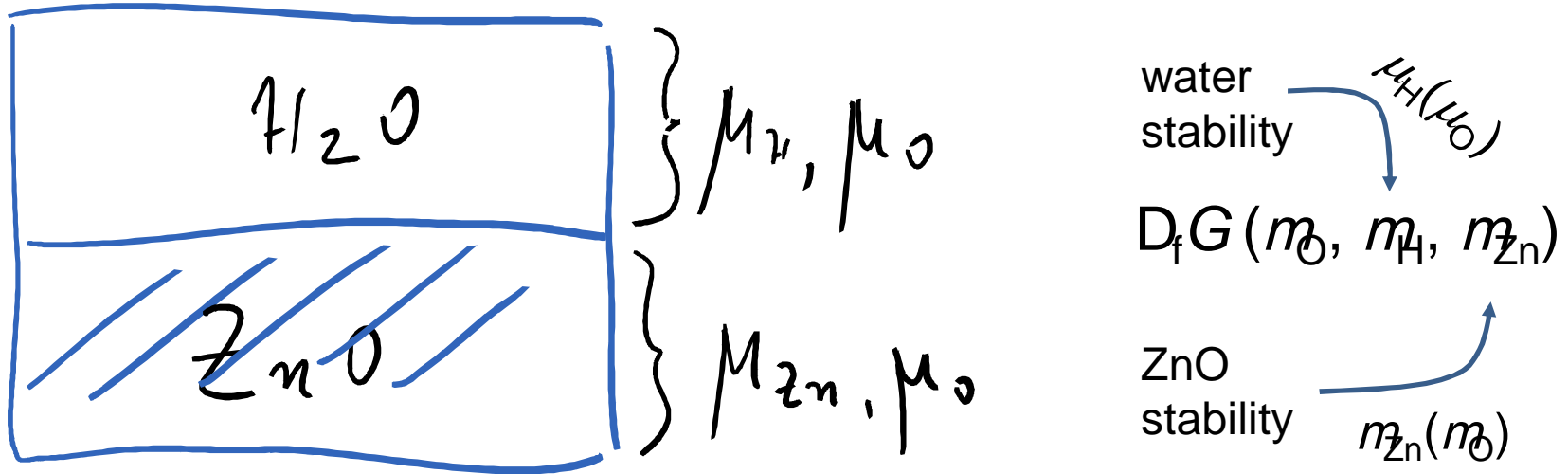

$$m_{\text{O}}(pH, U) = D_f G[\text{H}_2\text{O}] - 2\{e(U - U_{\text{SHE}}) - k_B T \ln 10 \text{ pH}\}$$

Considered surface phases on ZnO (0001)



- Considered ~ 50 surface phases

Clean surface

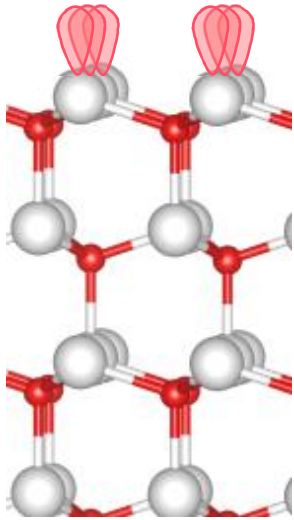

Clean
Zn(0001)-Zn

OH-adsorbed phases

0.11ML ~ 1ML OH

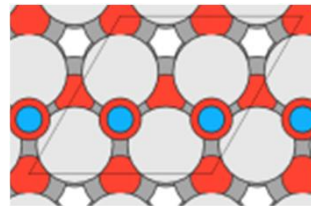

$p(2 \times 2)$ -0.5ML OH

$p(2 \times 2)$ models

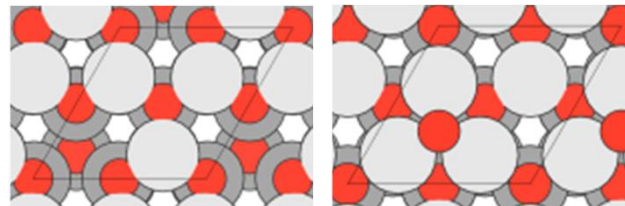

$p(2 \times 2)$ - V_{Zn} $p(2 \times 2)$ - O_{ad}

Triangular phases

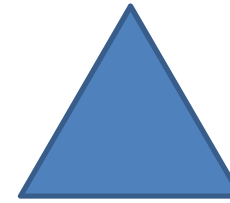

$n^2 \sim n^7$

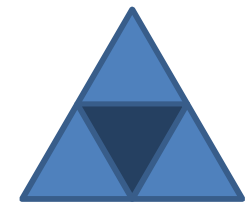

$n^6 n^3 \sim n^7 n^3$

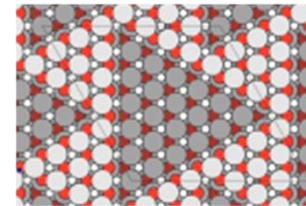

$p(\sqrt{48} \times \sqrt{48})-n^7$

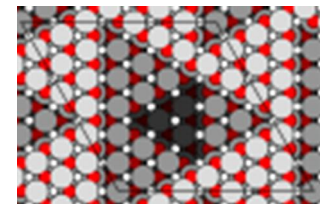

$p(\sqrt{48} \times \sqrt{48})-n^7 n^3$

- $p(\sqrt{12} \times \sqrt{12})$
-1/6ML O and 1/6ML OH

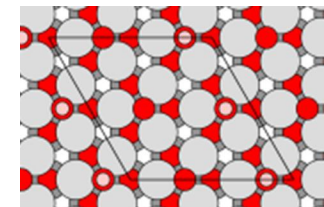

G. Kresse, O. Dulub, and U. Diebold, Phys. Rev. B **68**, 245409 (2003)

M. Valtiner, M. Todorova, G. Grundmeier, and J. Neugebauer, Phys. Rev. Lett. **103**, 065502 (2009)

Surface Pourbaix Diagram of ZnO(0001)



Calculation without solvent

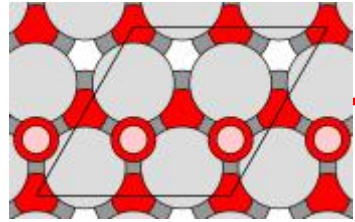

p(2x2)-OH 0.50 ML

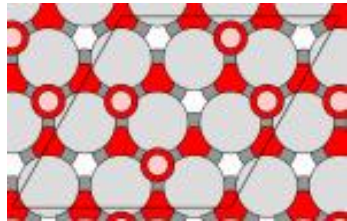

p(3x3)-OH 0.44 ML

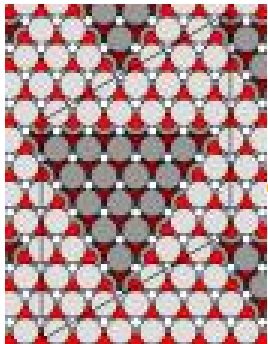

p($\sqrt{48}\times\sqrt{48}$)-n7

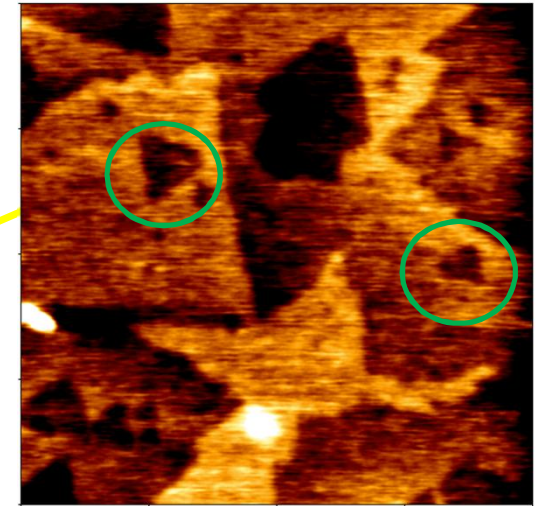
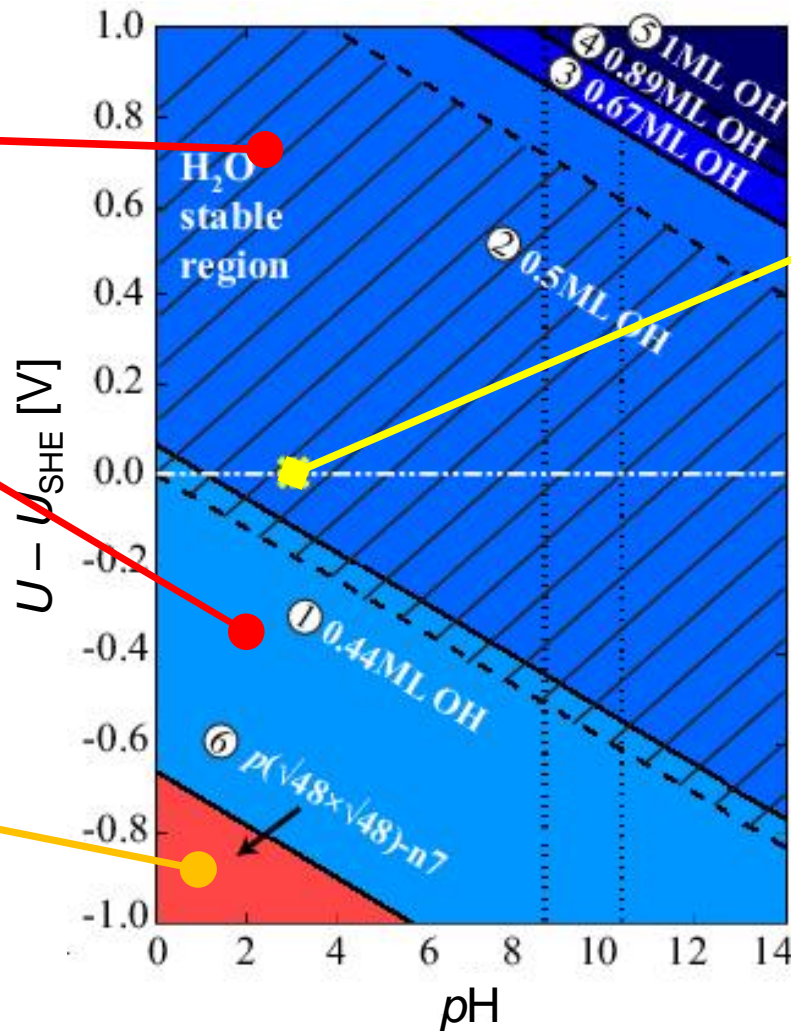

AFM image for ZnO (0001)-Zn in electrolyte

An OH adsorbate phase is stable at conditions where triangular reconstructions are observed

M. Valtiner, S. Borodin, and G. Grundmeier, *Langmuir* **24**, 5350 (2008)

Selective stabilization by the solvent



Calculation with solvent

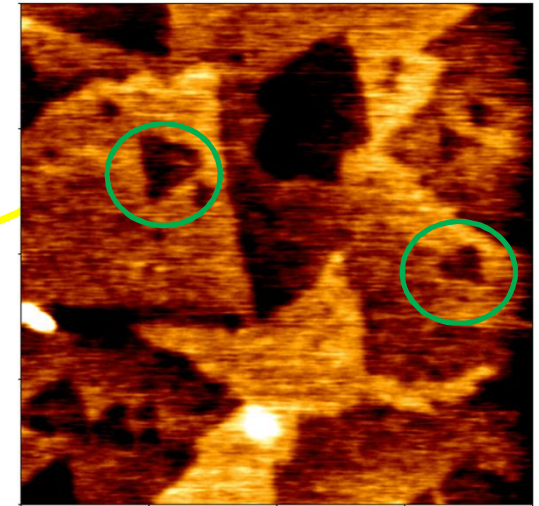
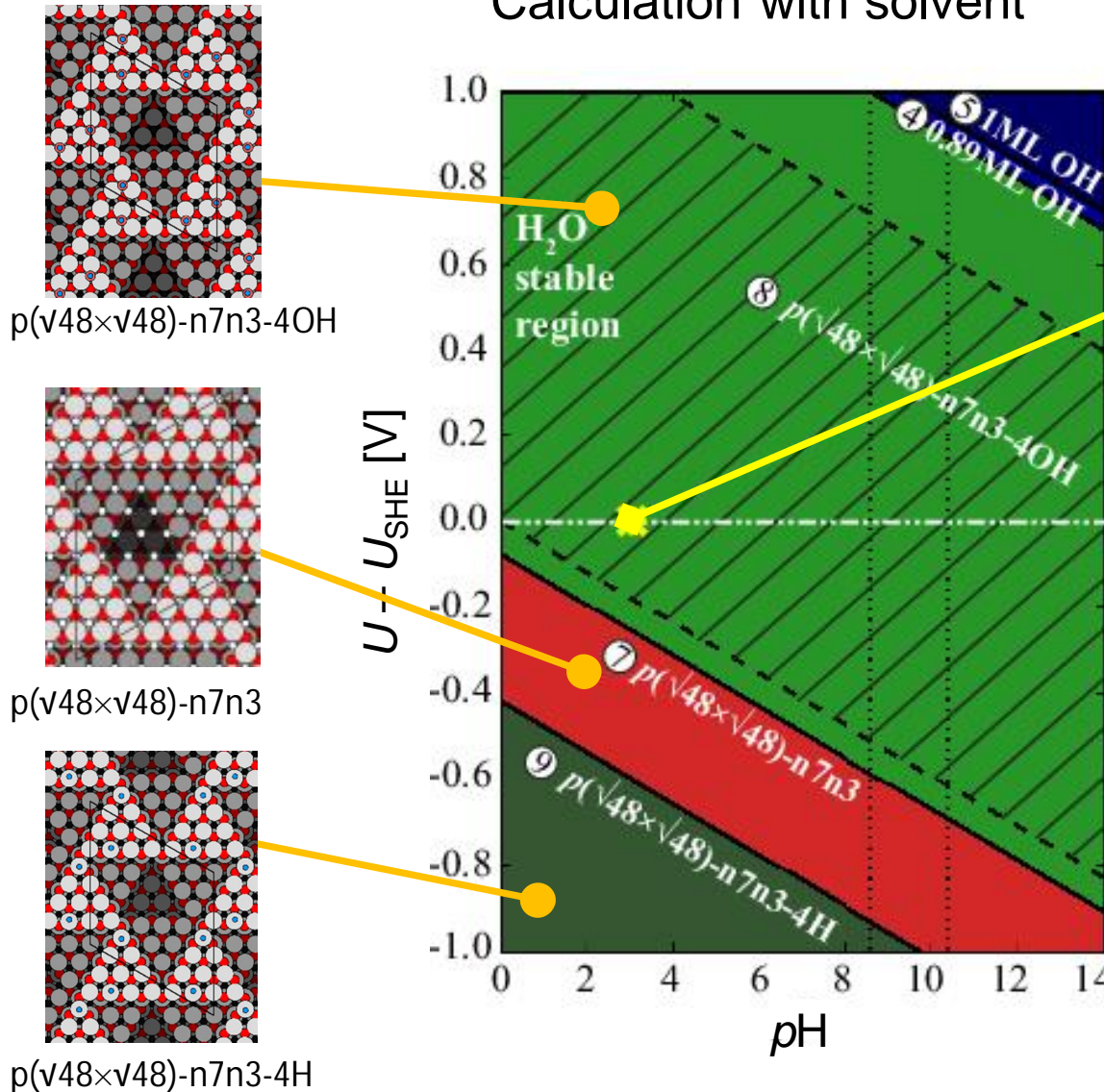

AFM image for ZnO (0001)-Zn in electrolyte

Solvation leads to the stabilization of structures which are thermodynamically unstable under normal conditions.

M. Valtiner, S. Borodin, and G. Grundmeier, *Langmuir* **24**, 5350 (2008)

Selectivity of solvation effects: Size effects

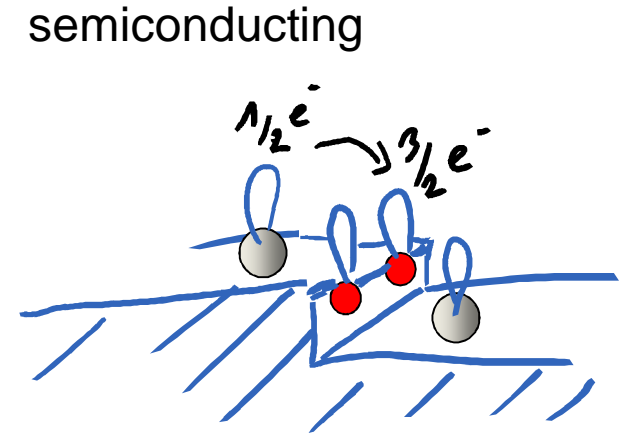
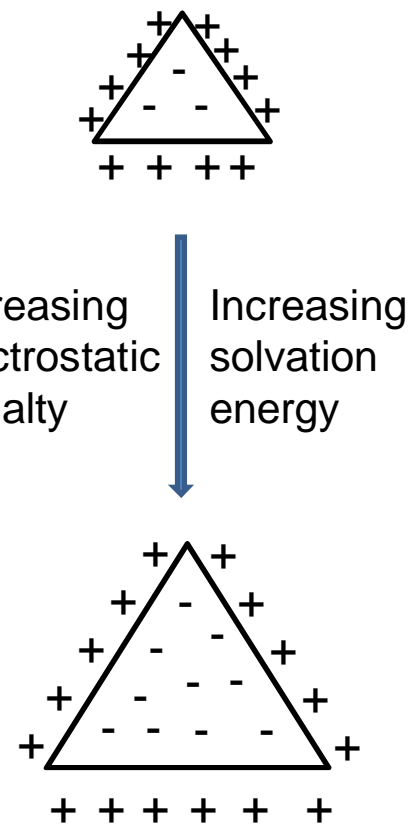
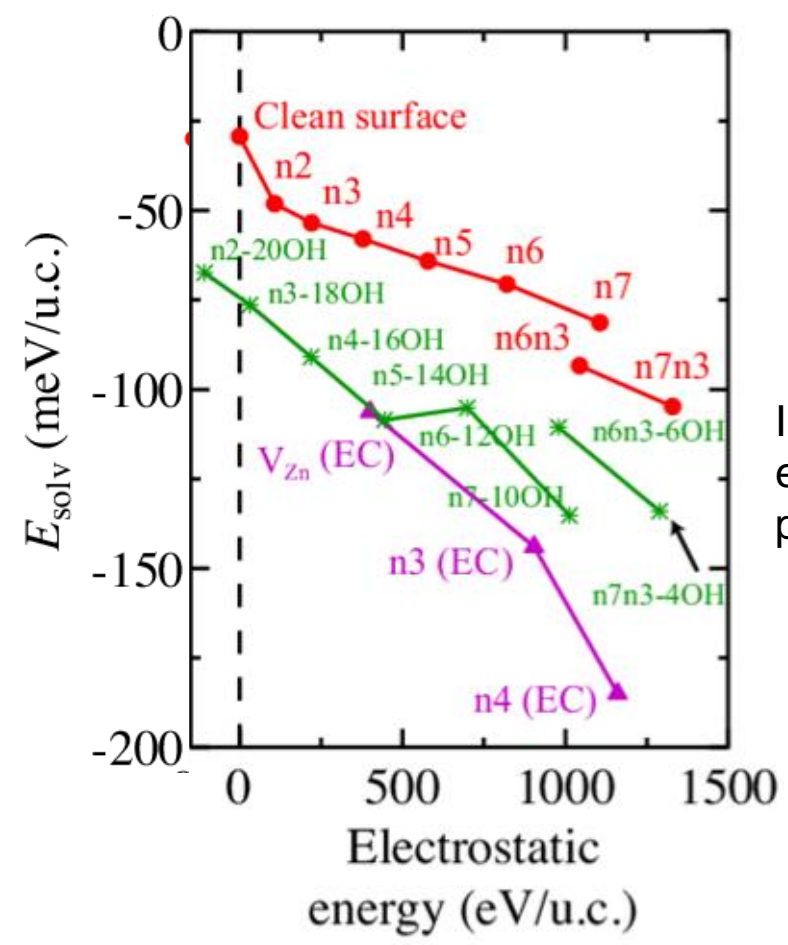

Poisson equation:
 $\Delta f = r$

Solvation energy is highly discriminating

- High electrostatic penalty in vacuum leads to a higher solvation energy gain

Selectivity of solvation effects: Metallicity

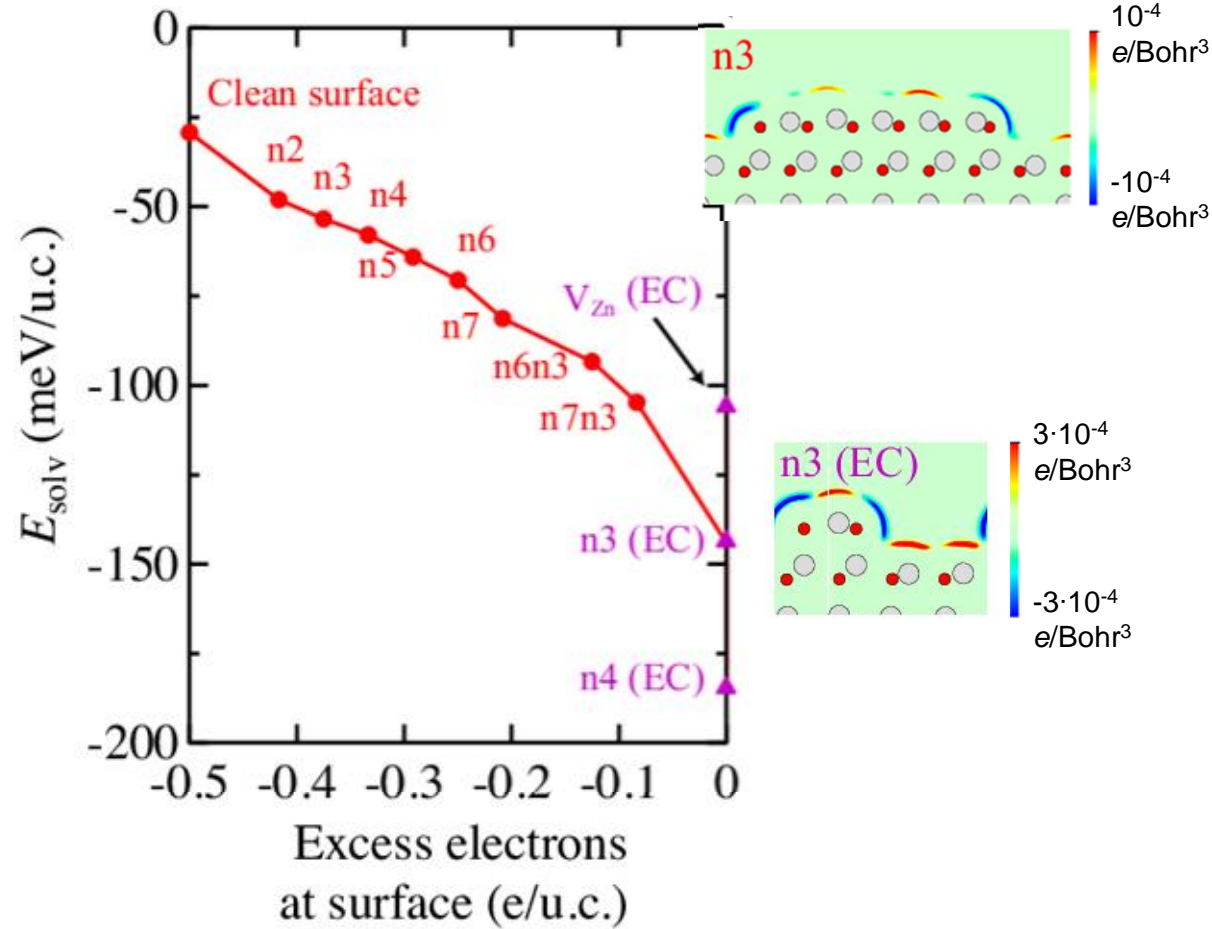

semiconducting

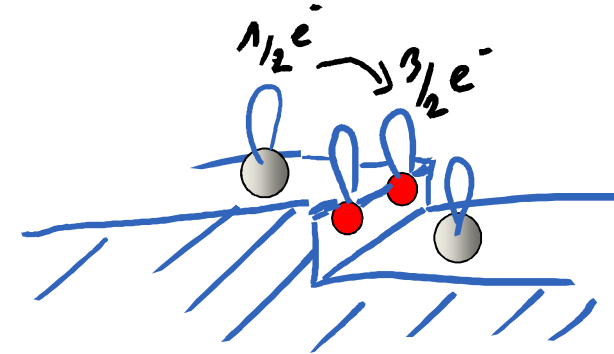

metallic

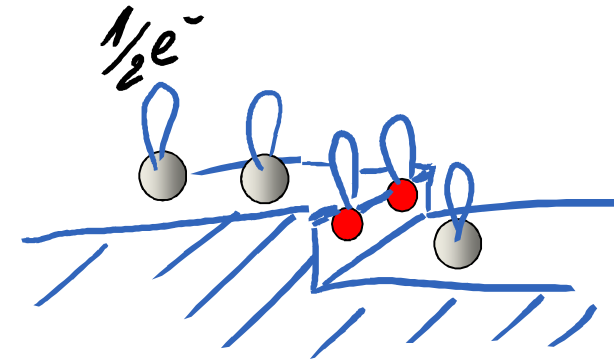

Solvation energy is highly discriminating

- High electrostatic penalty in vacuum leads to a higher solvation energy gain

Coarse graining water:

- useful when accounting for the screening properties of the solvent is sufficient

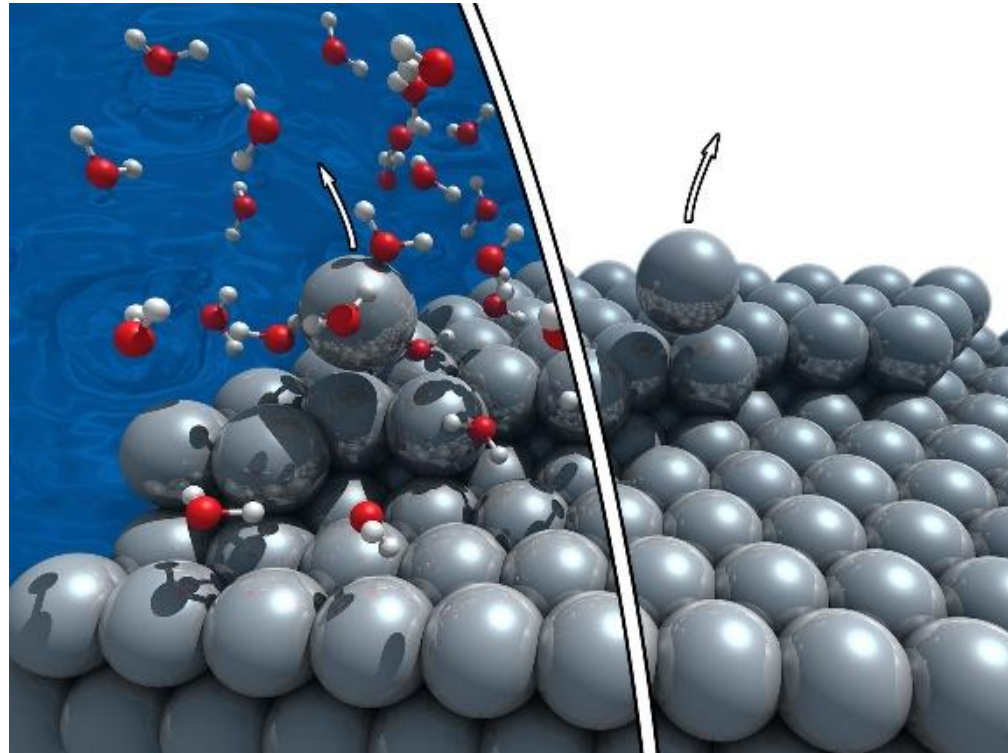

Explicit information about the geometric and/or the electronic structure is needed:

- Dissolution
- Reactions
- Redox levels, level alignment

Anoop Kishore Vatti



Benchmark:
Ion formation energies in water

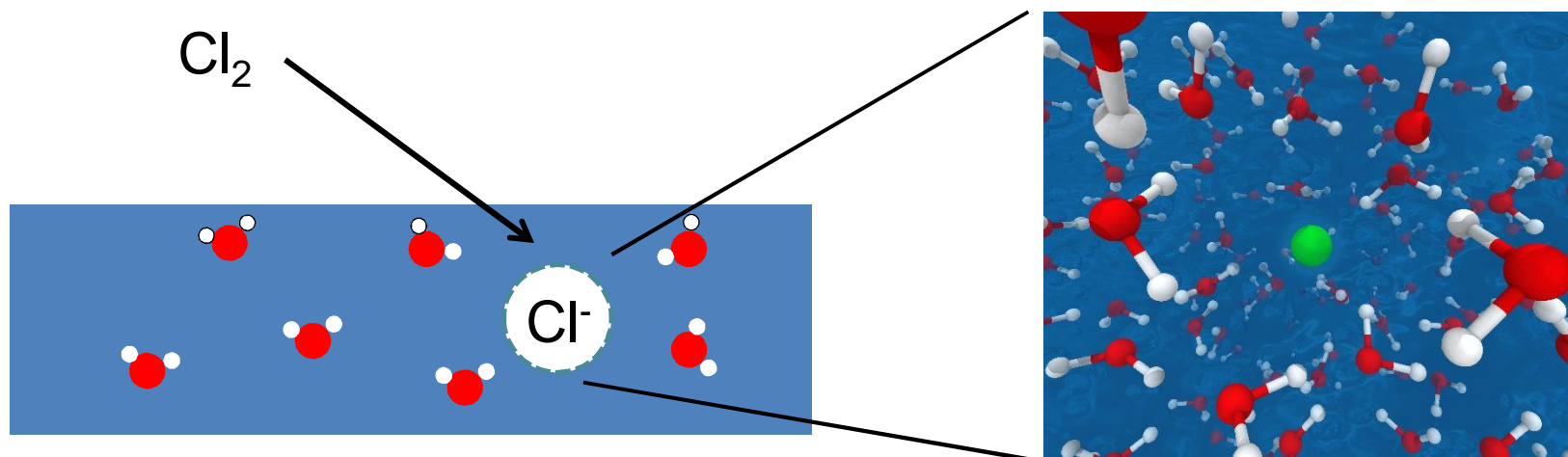

Semiconductor defect chemistry in a nutshell



Formation energies:

$$D_f G_{\text{defect}}(\text{ZnO} : V_O^q) = D E_{\text{tot}}(\text{ZnO} : V_O^q) + m_\delta + q E_{\text{Fermi}}$$

Defect concentration:

$$c_{\text{defect}} = e^{-D_f G_{\text{defect}} / k_B T}$$

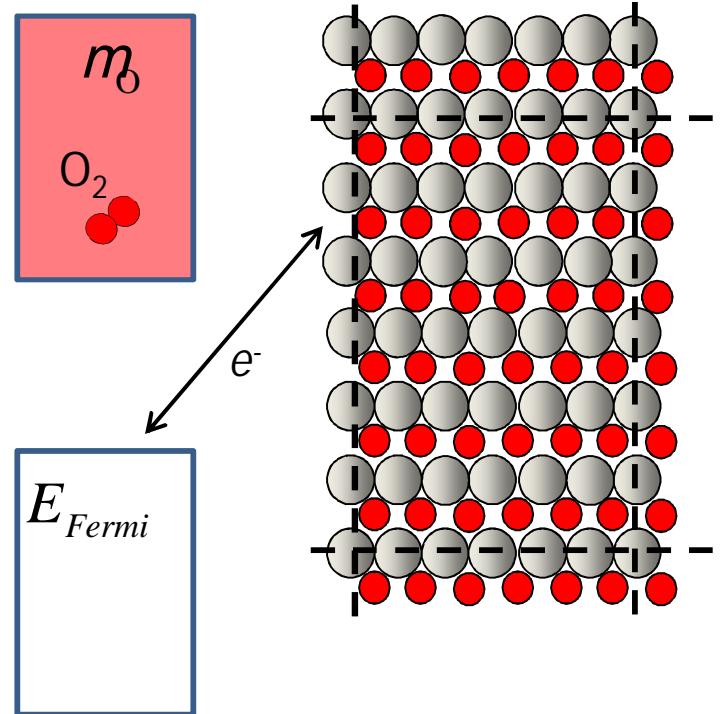

Formation energies:
$$\Delta_f G_{\text{defect}}(\text{ZnO} : V_O^q) = \Delta E_{\text{tot}}(\text{ZnO} : V_O^q) + m_{\text{O}} + qE_{\text{Fermi}}$$

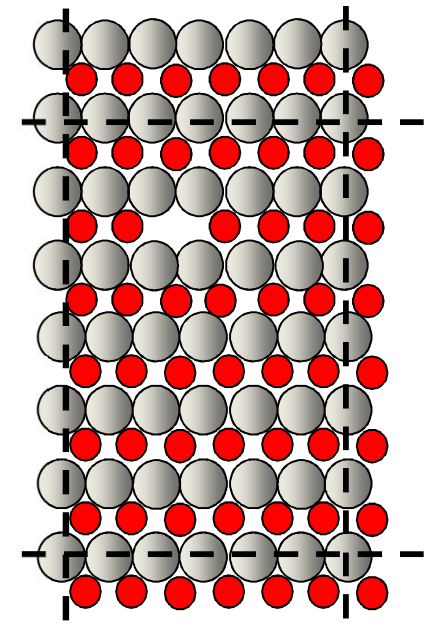
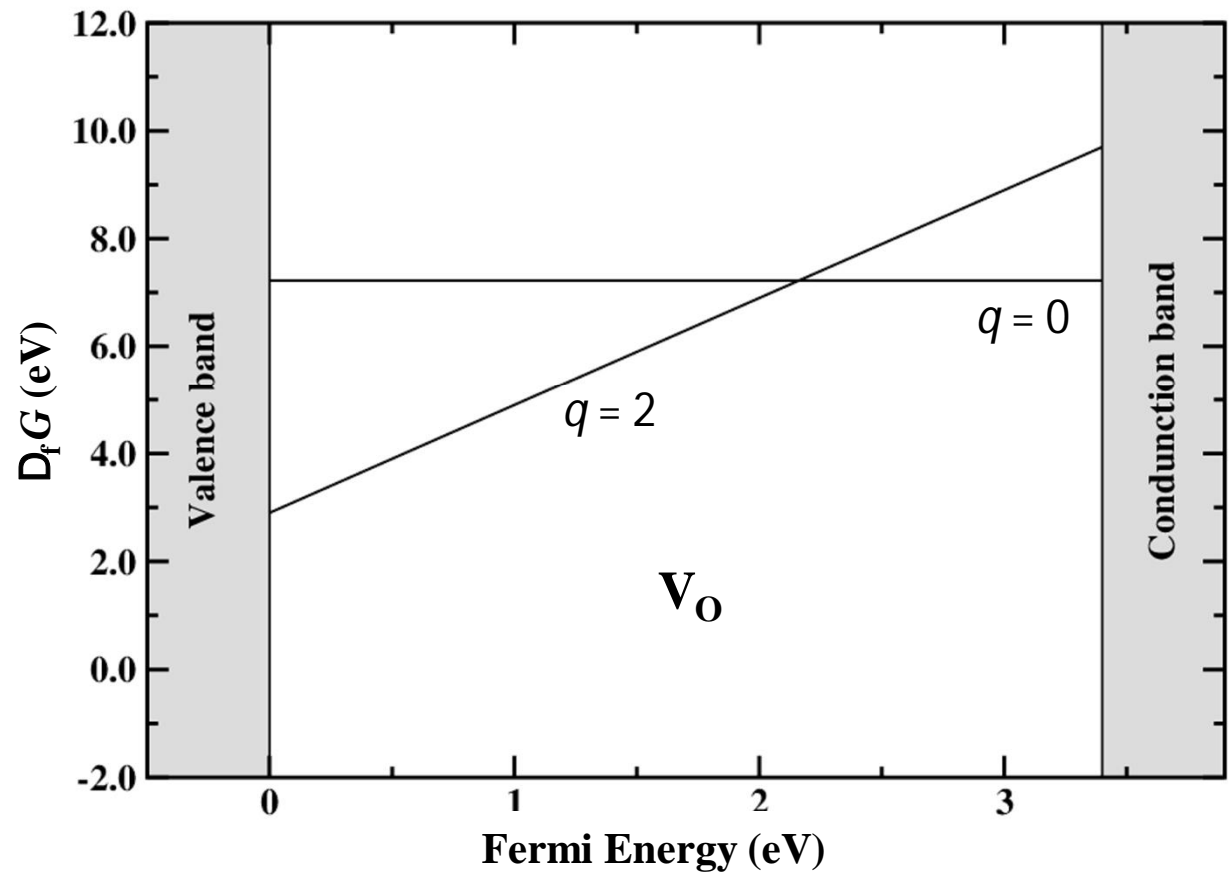

- Defect energy for a given point defect in any charge state can be computed
- Single defect rather than a charge neutral reaction can be computed

Semiconductor defect chemistry in a nutshell



Formation energies:
$$\Delta_f G_{\text{defect}}(\text{ZnO} : V_{\text{O}}^q) = \Delta E_{\text{tot}}(\text{ZnO} : V_{\text{O}}^q) + m_{\text{O}} + qE_{\text{Fermi}}$$

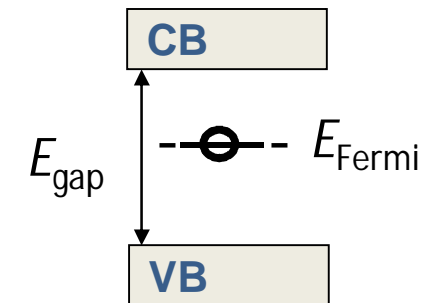
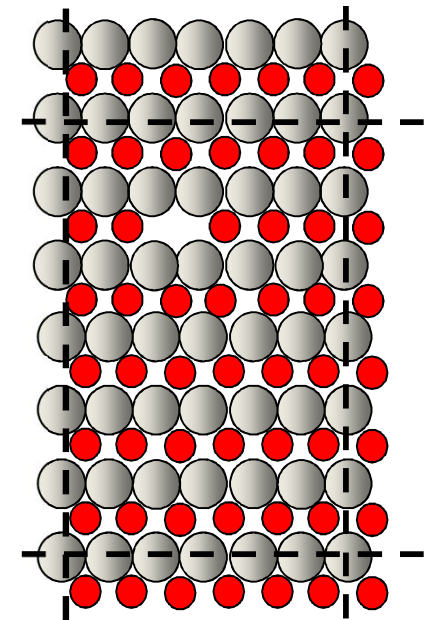
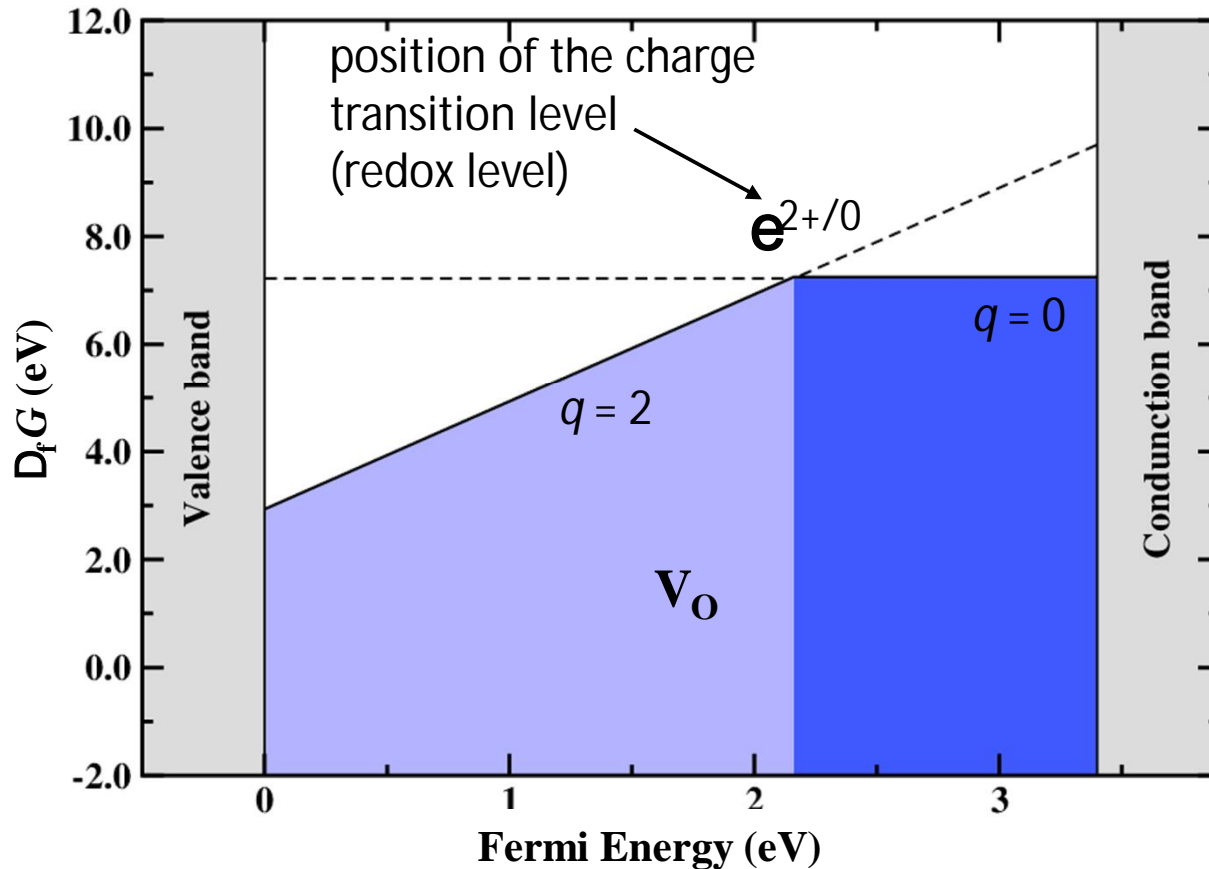

- Defect energy for a given point defect in any charge state can be computed
- Single defect rather than a charge neutral reaction can be computed

Calculating ion formation energies



$$D_f G(\text{Cl}^-) = \underbrace{\langle E_{\text{tot}}(\text{Cl}^- : \text{H}_2\text{O}) \rangle_{T,p}}_{10^4 \dots 10^5 \text{ configurations}} + \underbrace{\langle E_{\text{tot}}(\text{H}_2\text{O}) \rangle_{T,p}}_{10^4 \dots 10^5 \text{ configurations}} - m_{\text{Cl}} + qE_{\text{Fermi}} + TDS$$

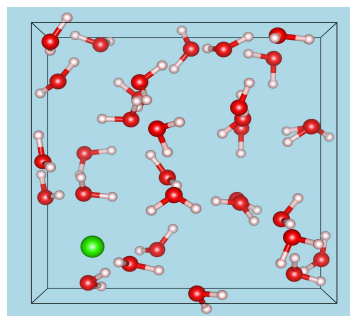

-

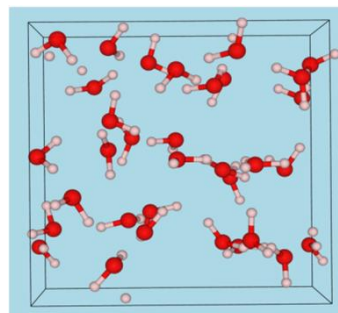

-

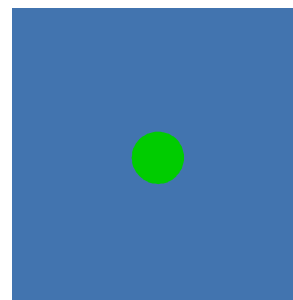

+

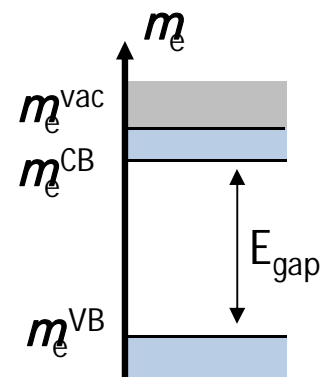

$\langle E_{\text{tot}}(\text{Cl}^- : \text{H}_2\text{O}) \rangle_{T,p}$

$\langle E_{\text{tot}}(\text{H}_2\text{O}) \rangle_{T,p}$

m_{Cl}

$m_e \sim E_F$

Ab initio MD

Reservoirs for the defect species and the charge
(\otimes Alignment)

Band gap

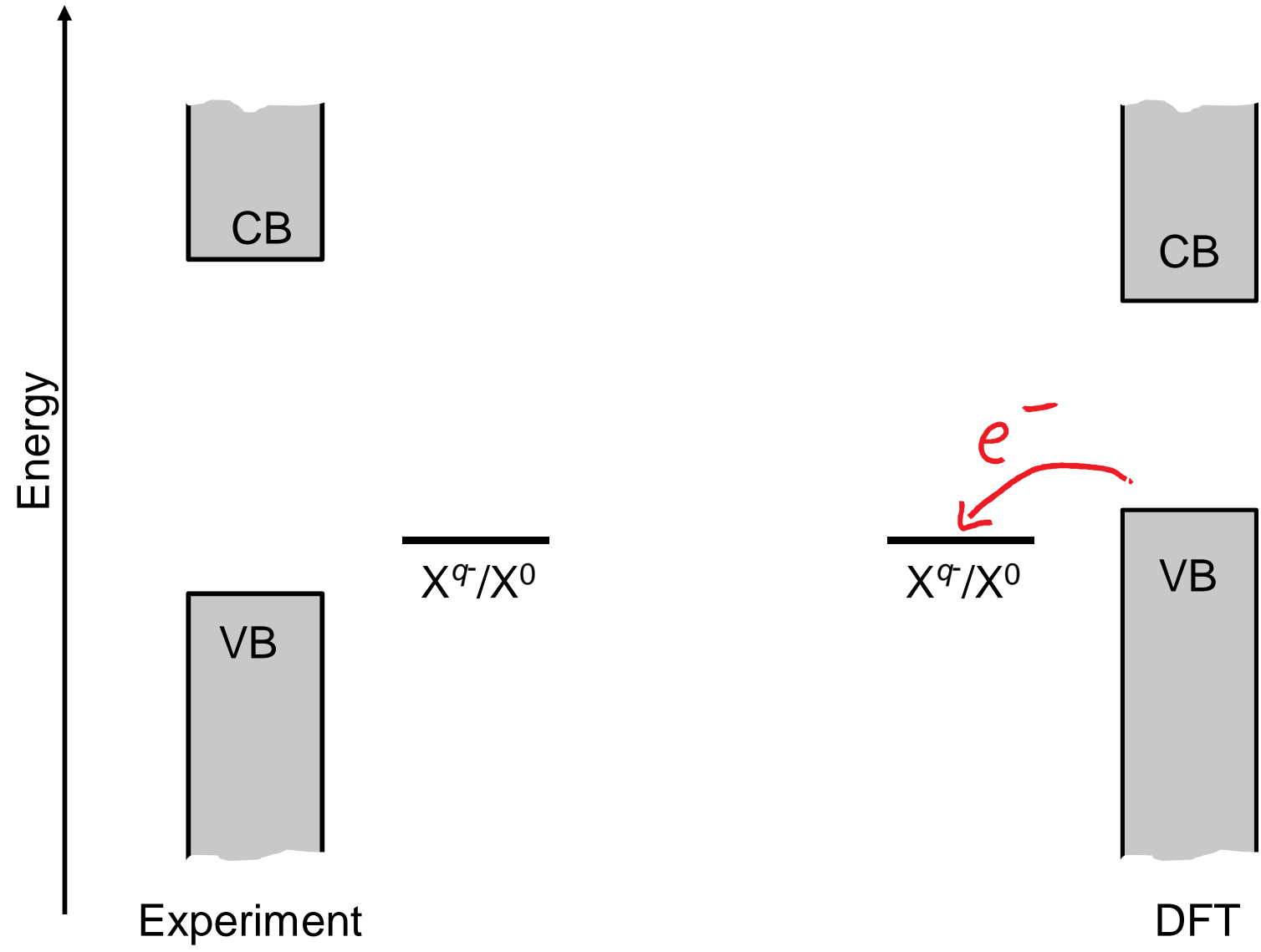

Conventional DFT exchange correlation potential:
GGA-PBE

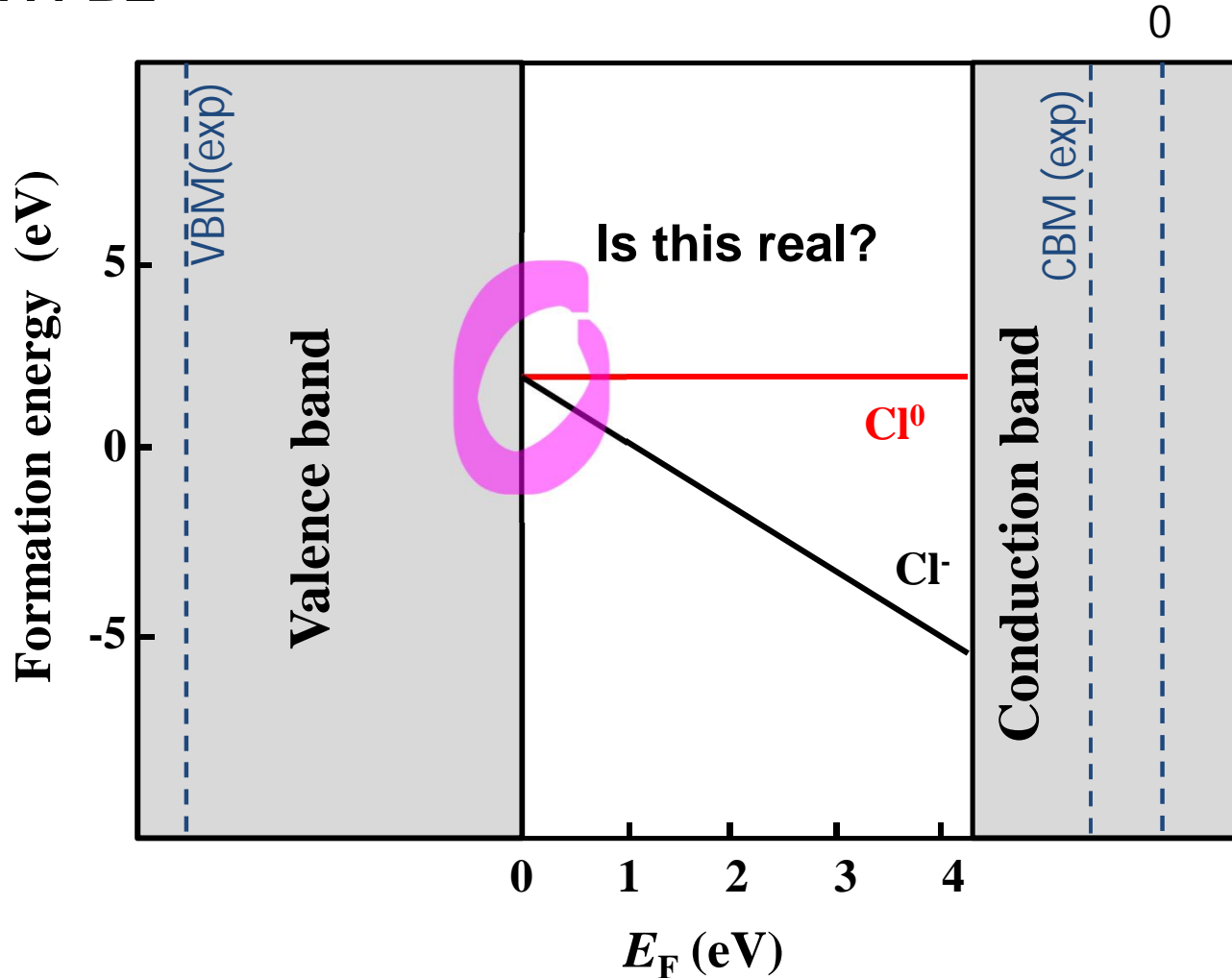

Hybrid DFT exchange correlation potential:

PBE0

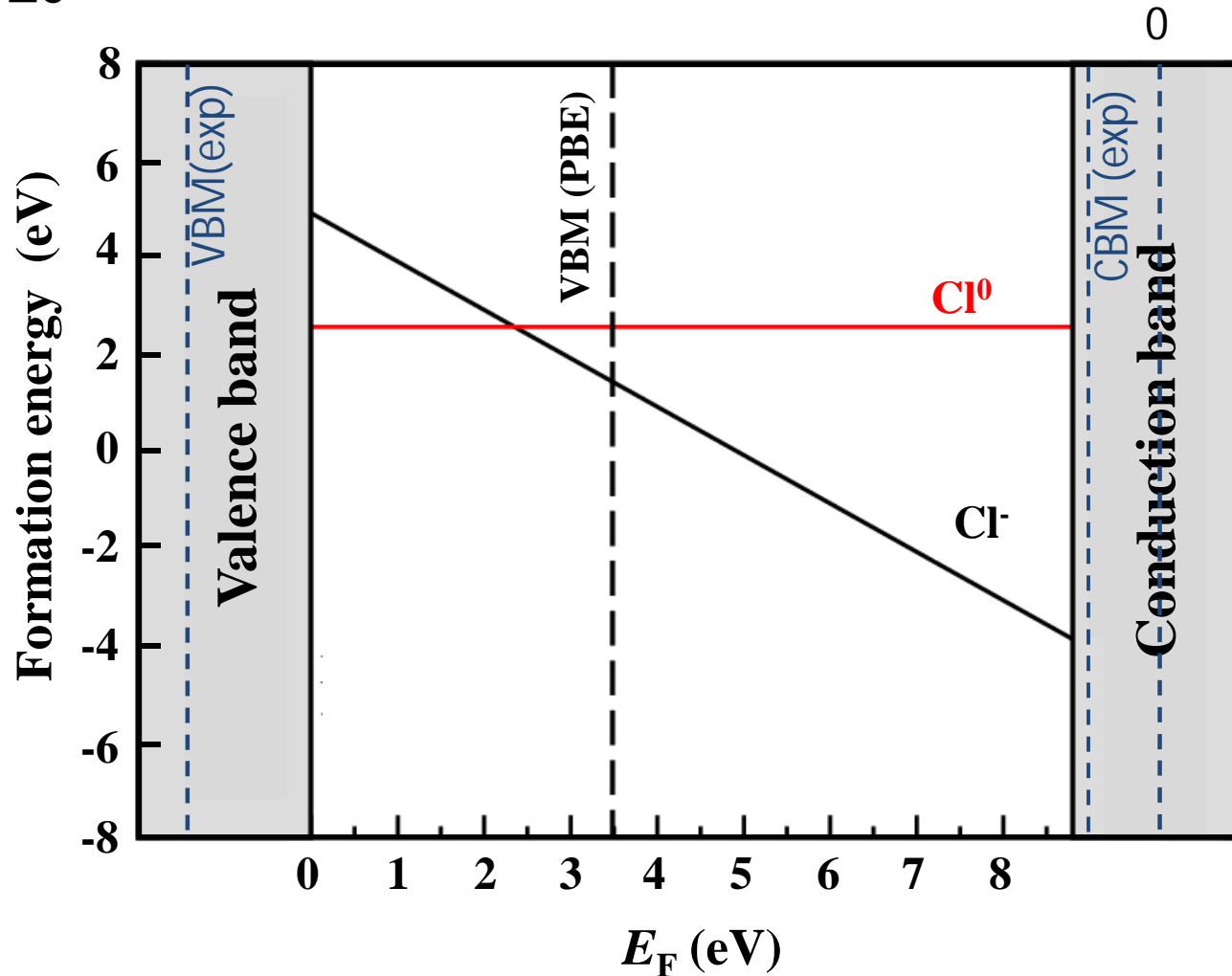

Band gap of water and alignment

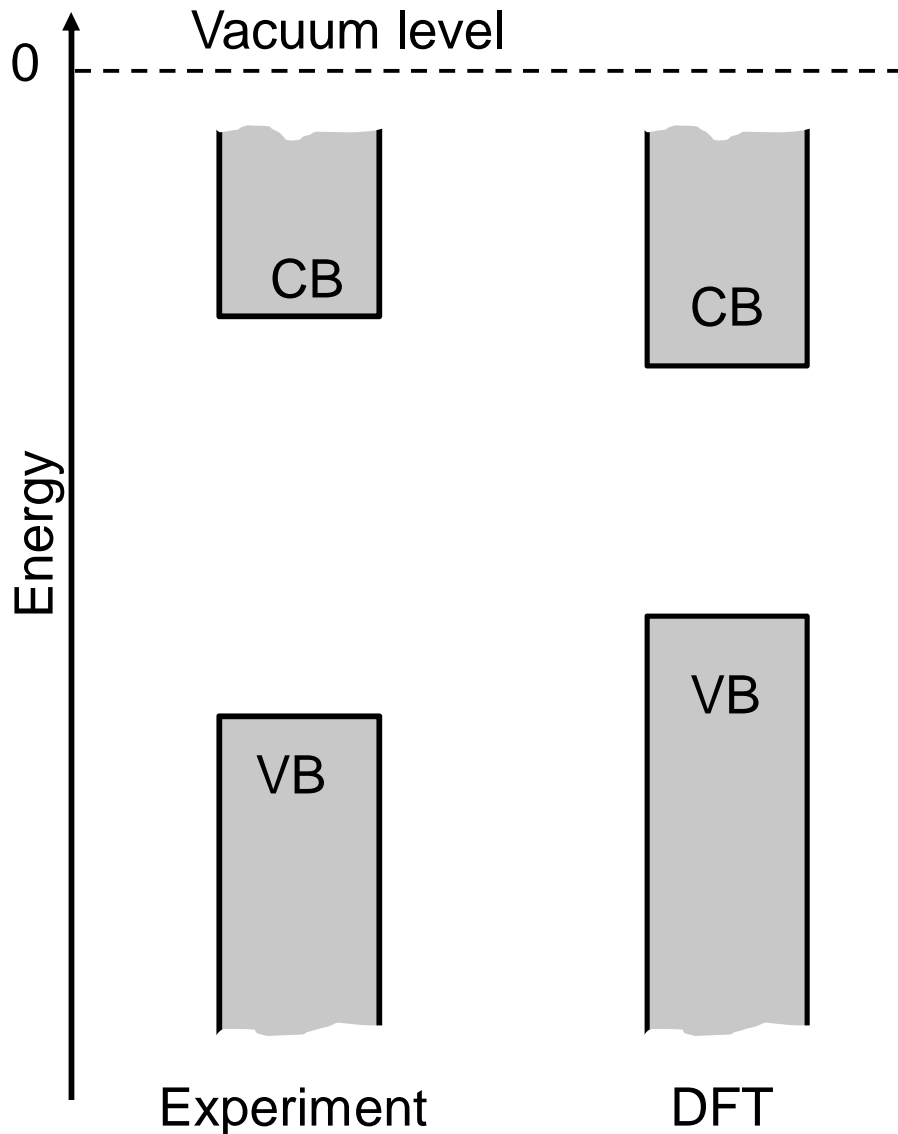

Use electrostatic potential to align the band gaps

- Work function (metals)
- Ionization Potential/ Electron affinity (semiconductors)

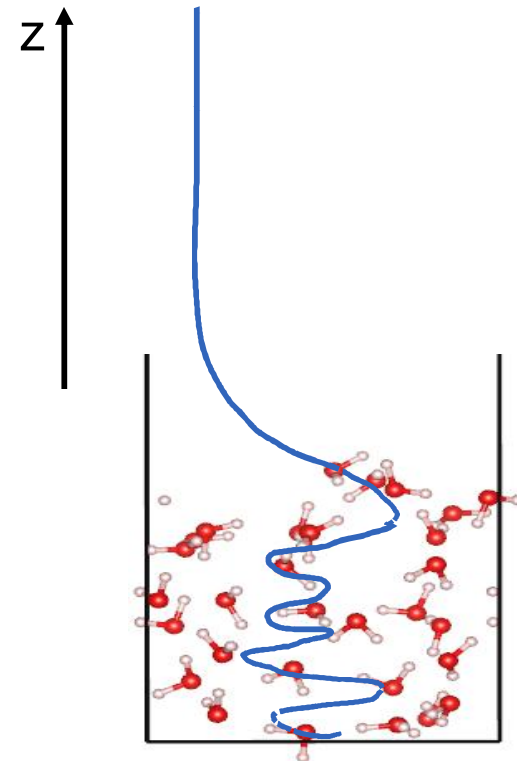

Use electrostatic potential to align the band gaps

- Work function (metals)
- Ionization Potential/ Electron affinity (semiconductors)

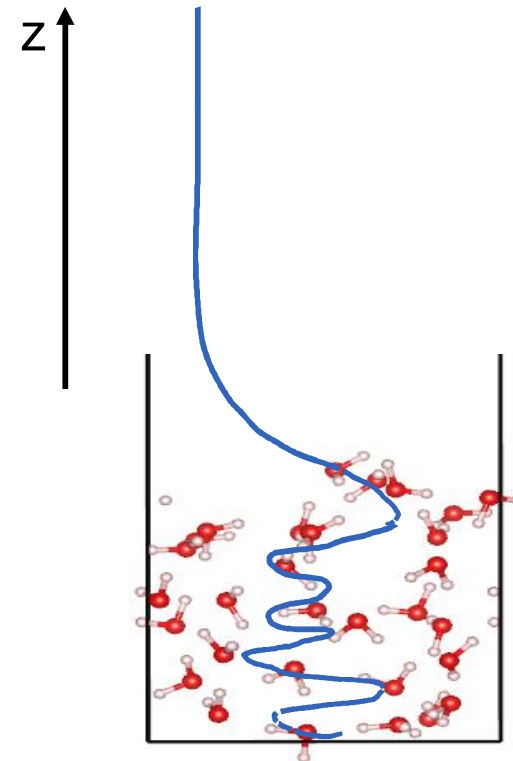
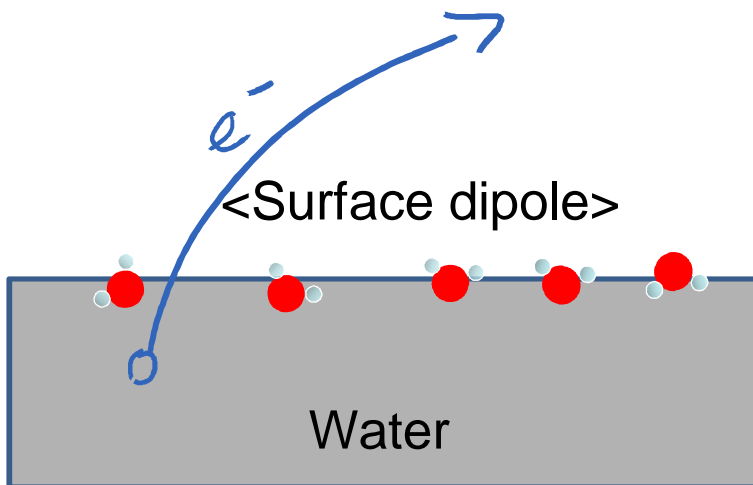
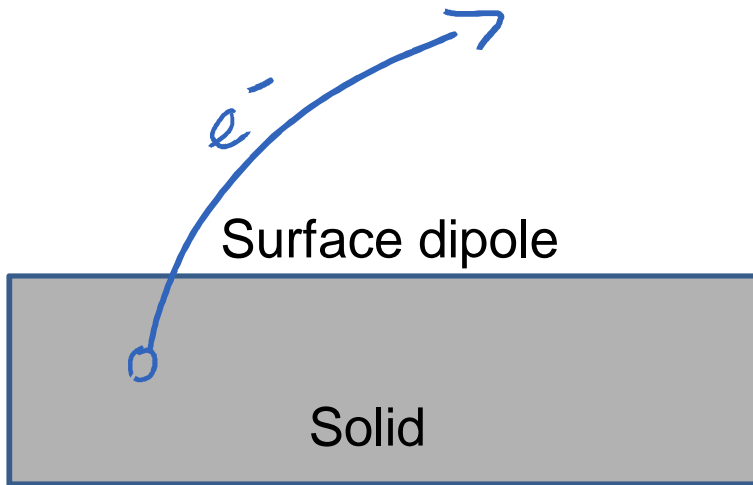

Band gap of water

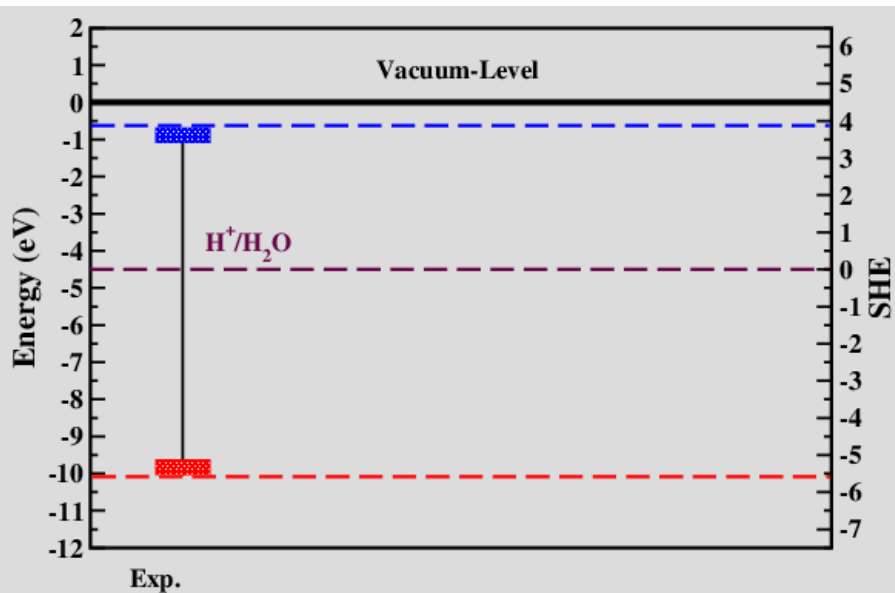

Sample phase space using a classical potential (TIP3P)



Extract from the obtained trajectory uncorrelated structures



Perform DFT calculations at different levels of xc-functionals

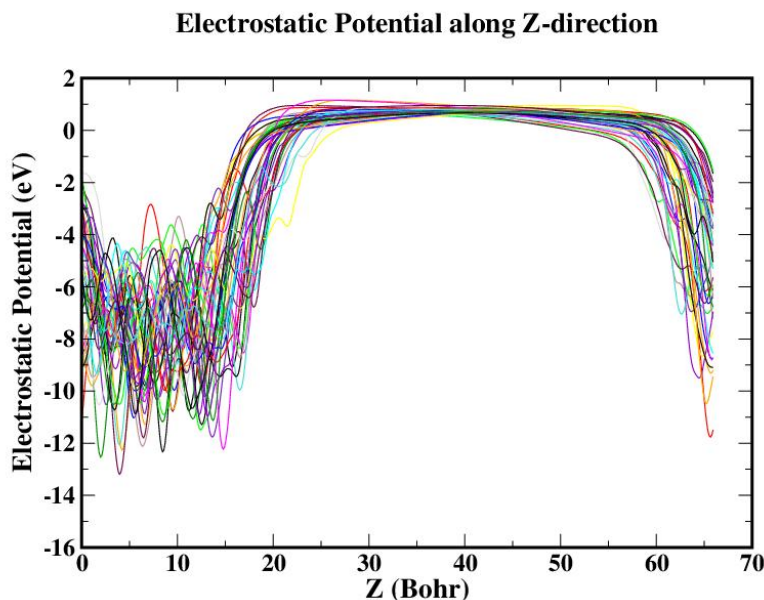
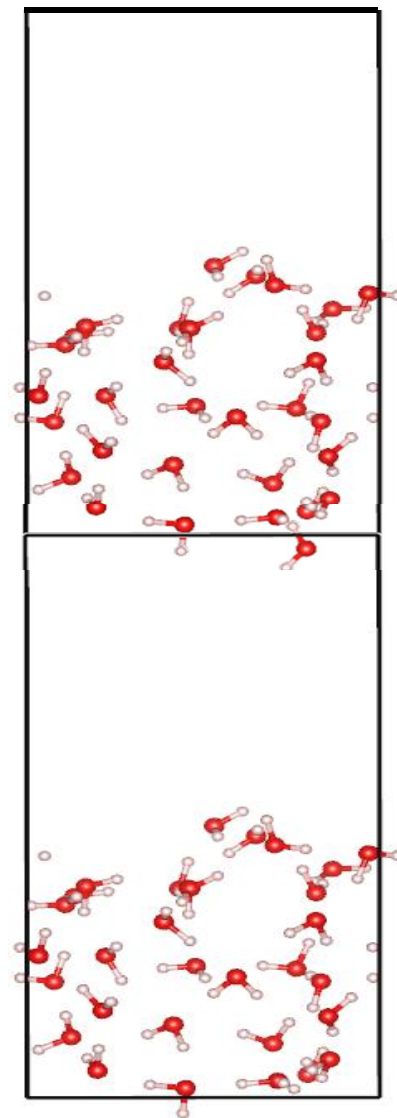

T.A.Pham et al. , Phys. Rev. B **89**, 060202 (2014)
C.Freysoldt et al. , Rev. Mod. Phys. **86**, 253 (2014)

Band gap of water

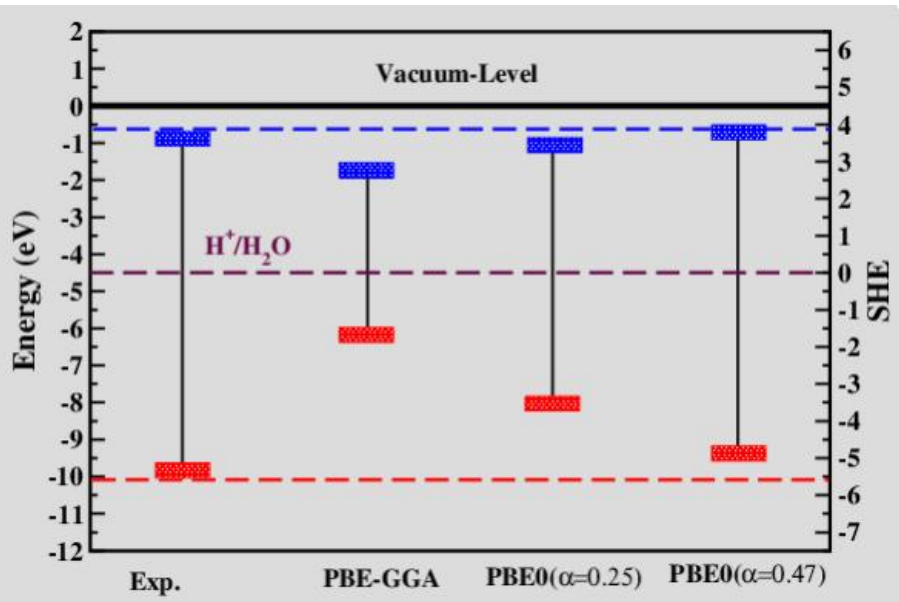

Sample phase space using a classical potential (TIP3P)



Extract from the obtained trajectory uncorrelated structures



Perform DFT calculations at different levels of xc-functionals

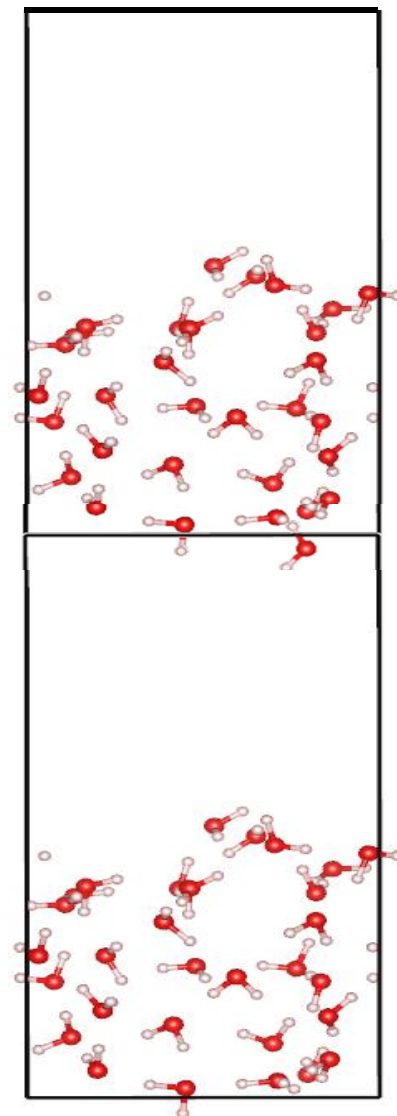

Electrostatic Potential along Z-direction

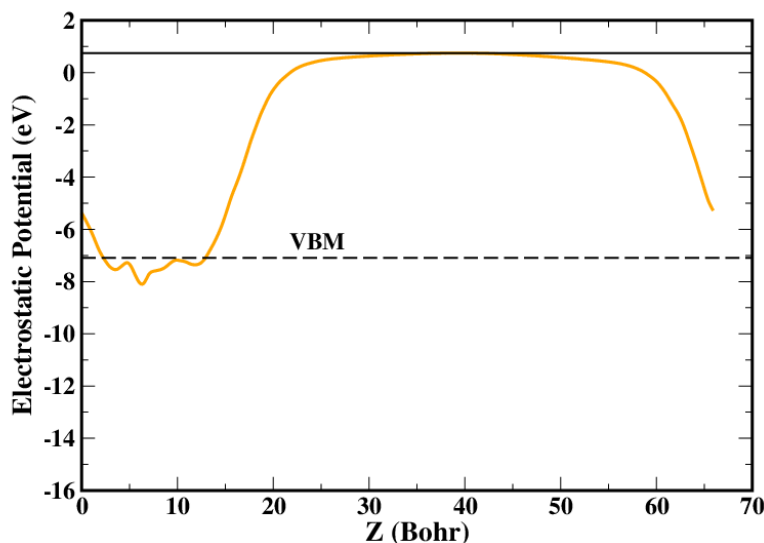

T.A.Pham et al. , *Phys. Rev. B* **89**, 060202 (2014)
 C.Freysoldt et al. , *Rev. Mod. Phys.* **86**, 253 (2014)

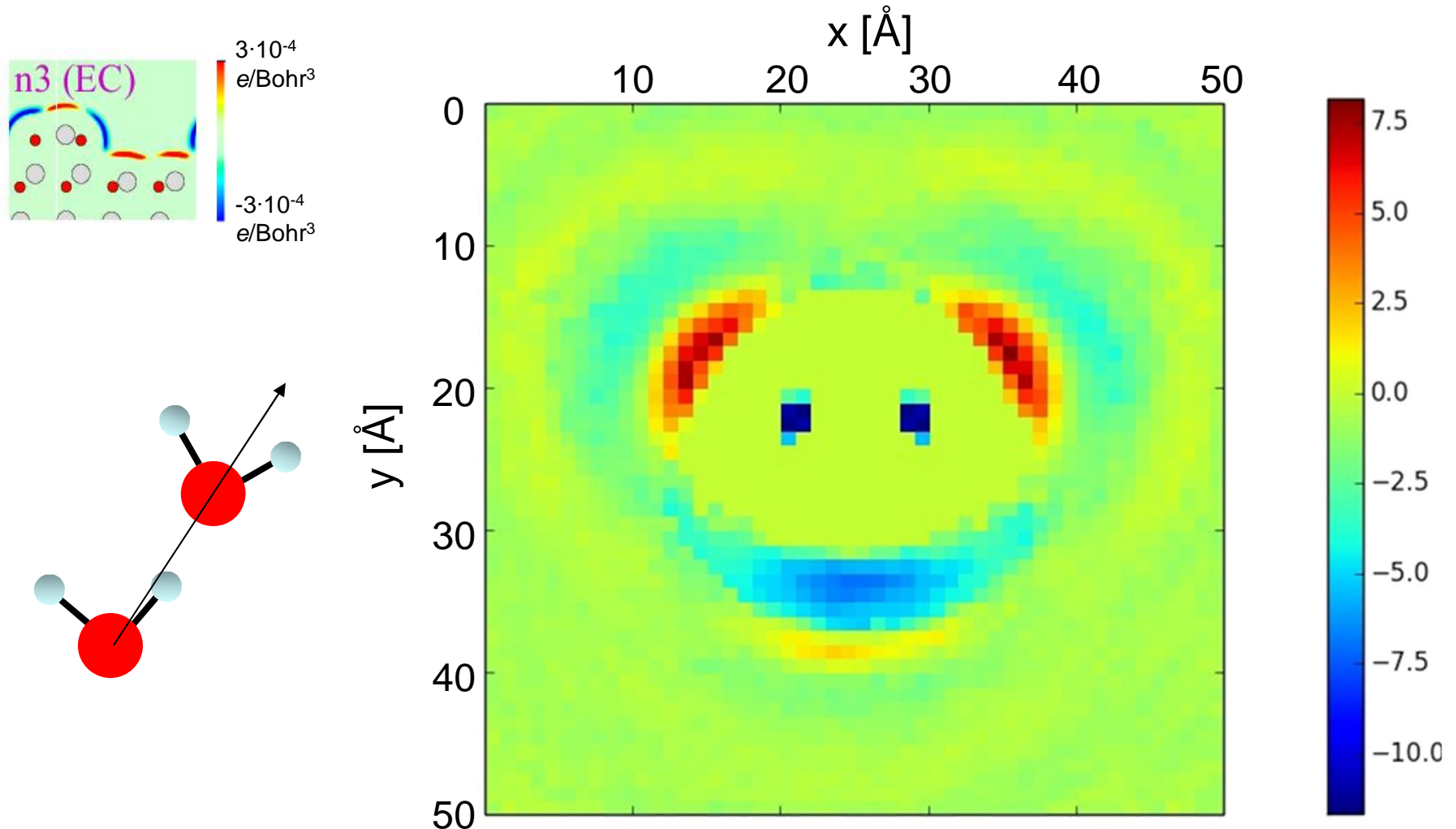

Can we utilize our knowledge about the correlations in water to develop coarse graining models?

Coarse graining models for water

- extremely efficient to account for the solvent
- useful for accessing stability and constructing phase diagrams
- limited applicability when the structure of the solvent becomes important

Explicit water

- computationally expensive
- contain all the needed information about electronic and geometric structure

Can we use the knowledge we have about the correlations in water to design better sampling strategies?

Group (former & present):

Su-Ting Cheng

Klaus-Dieter Bauer

Mehmet Ilhan

Anoop Kishore Vatti

Suhyun Yoo

Sudarsan Surendralal

Moloud Aghayarzadeh

Colleagues at the MPIE

Jörg Neugebauer

Funding:

